



# DEEP ROB

Lecture 12  
Deep Learning Software  
University of Michigan | Department of Robotics



# Overview

## 1. One time setup:

- Activation functions, data preprocessing, weight initialization, regularization

## 2. Training dynamics:

- Learning rate schedules; hyperparameter optimization

## 3. After training:

- Model ensembles, transfer learning, large-batch training



# Model Ensembles

---

1. Train multiple independent models
2. At test time average their results:  
(Take average of predicted probability distributions, then choose argmax)

Enjoy 2% extra performance



# Model Ensembles: Tips and Tricks

Instead of training independent models, use multiple snapshots of a single model during training!

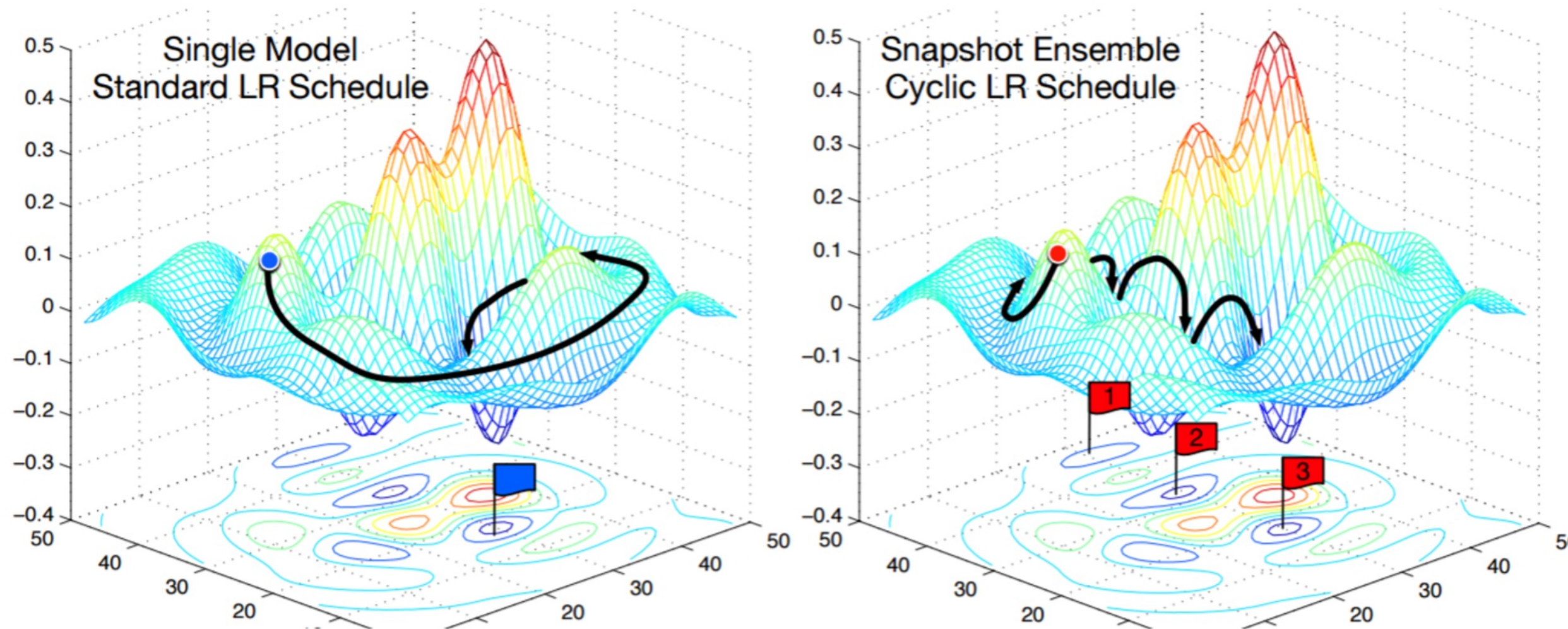

Loshchilov and Hutter, "SGDR: Stochastic gradient descent with restarts", arXiv 2016

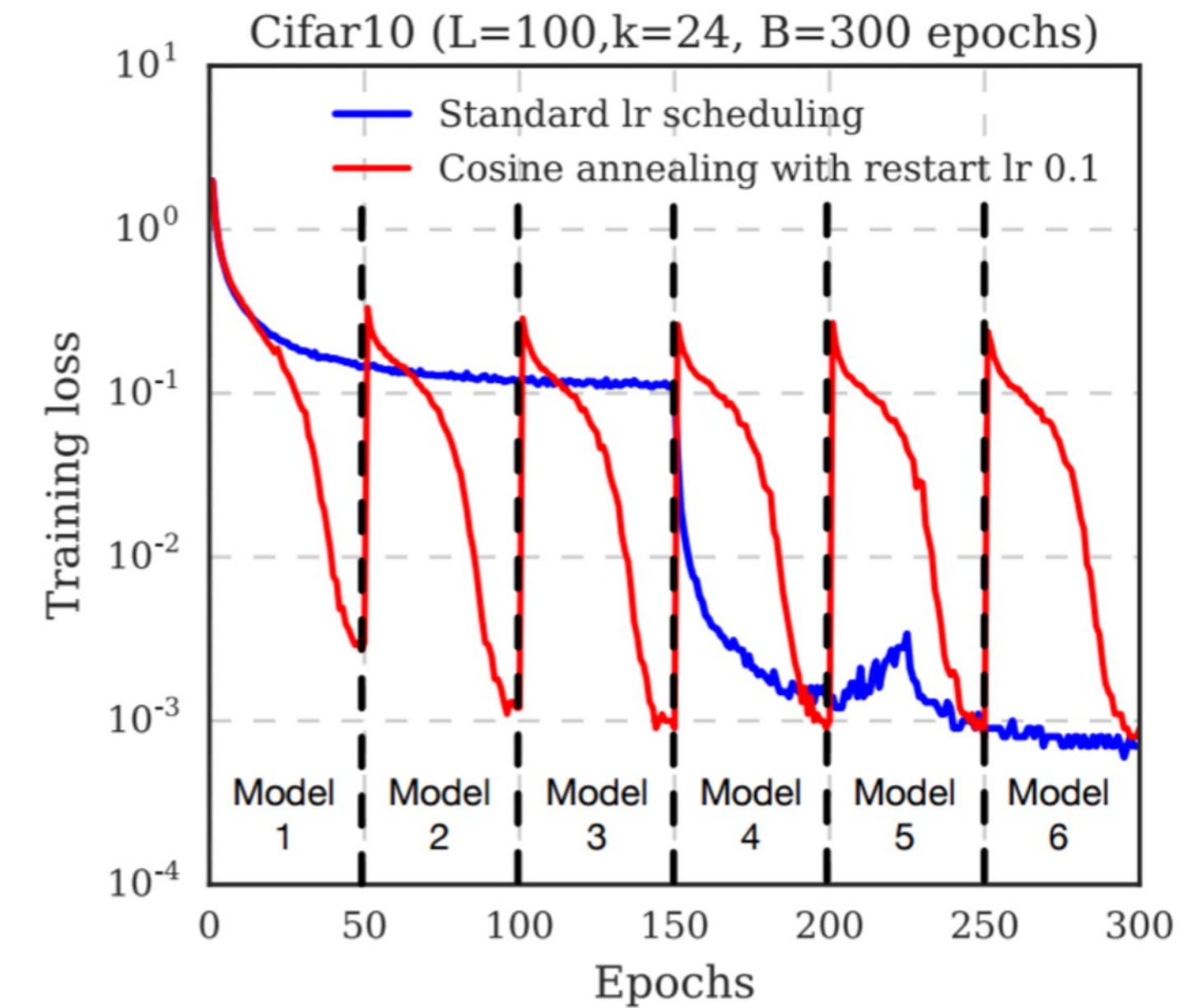

Huang et al, "Snapshot ensembles: train 1, get M for free", ICLR 2017  
Figures copyright Yixuan Li and Geoff Pleiss, 2017. Reproduced with permission.

Cyclic learning rate schedules can make this work even better!



# Model Ensembles: Tips and Tricks

Instead of using actual parameter vector, keep a moving average of the parameter vector and use that at test time (Polyak averaging)

```
while True:
    data_batch = dataset.sample_data_batch()
    loss = network.forward(data_batch)
    dx = network.backward()
    x += - learning_rate * dx
    x_test = 0.995*x_test + 0.005*x # use for test set
```

Polyak and Juditsky, "Acceleration of stochastic approximation by averaging", SIAM Journal on Control and Optimization, 1992.



# Transfer Learning

---

“You need a lot of data if you want to train / use CNNs”

What if data is limited?



# Transfer Learning with CNNs

## 1. Train on ImageNet



## 2. Use CNN as a feature extractor

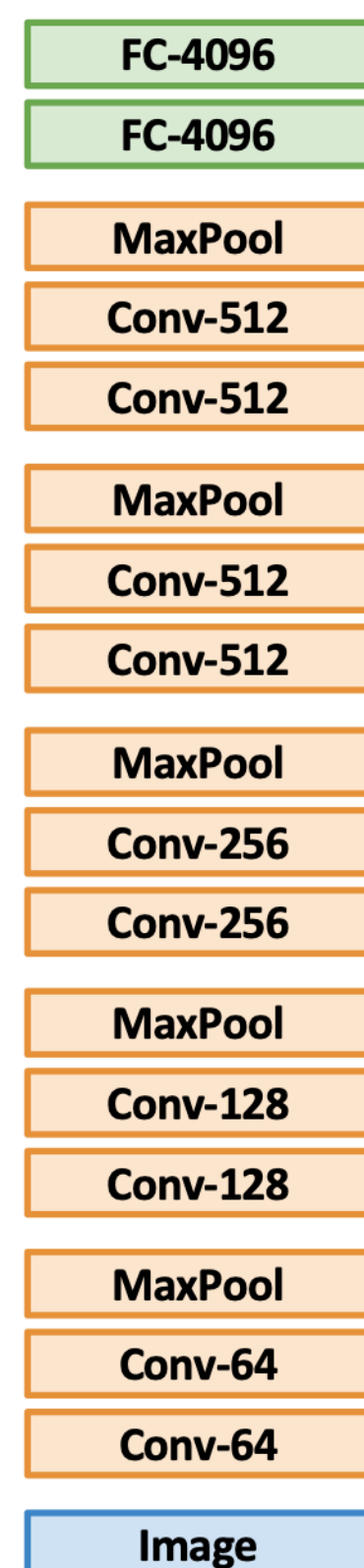

Remove last layer

Freeze these



# Transfer Learning with CNNs

## 1. Train on ImageNet

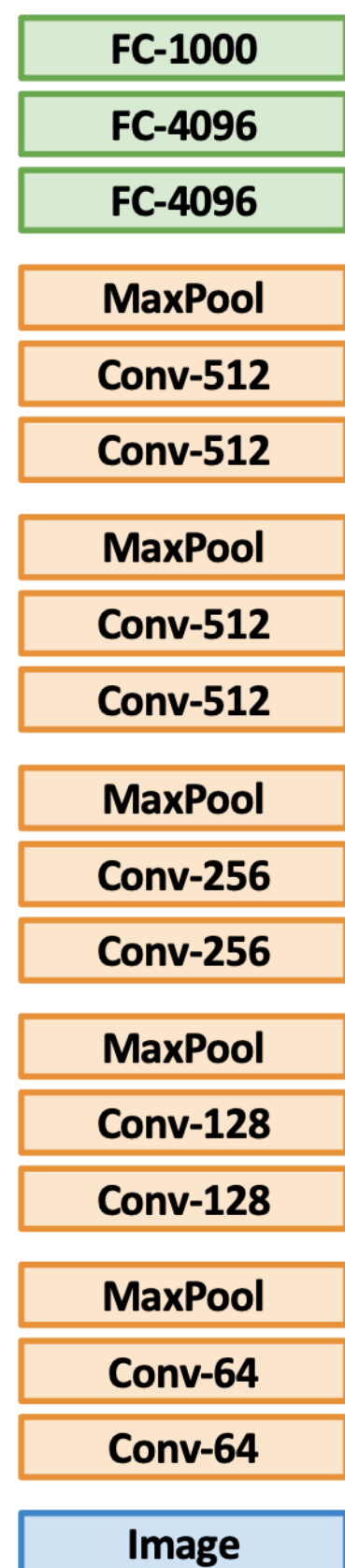

## 2. Use CNN as a feature extractor



Remove last layer

Freeze these

## Classification on Caltech-101

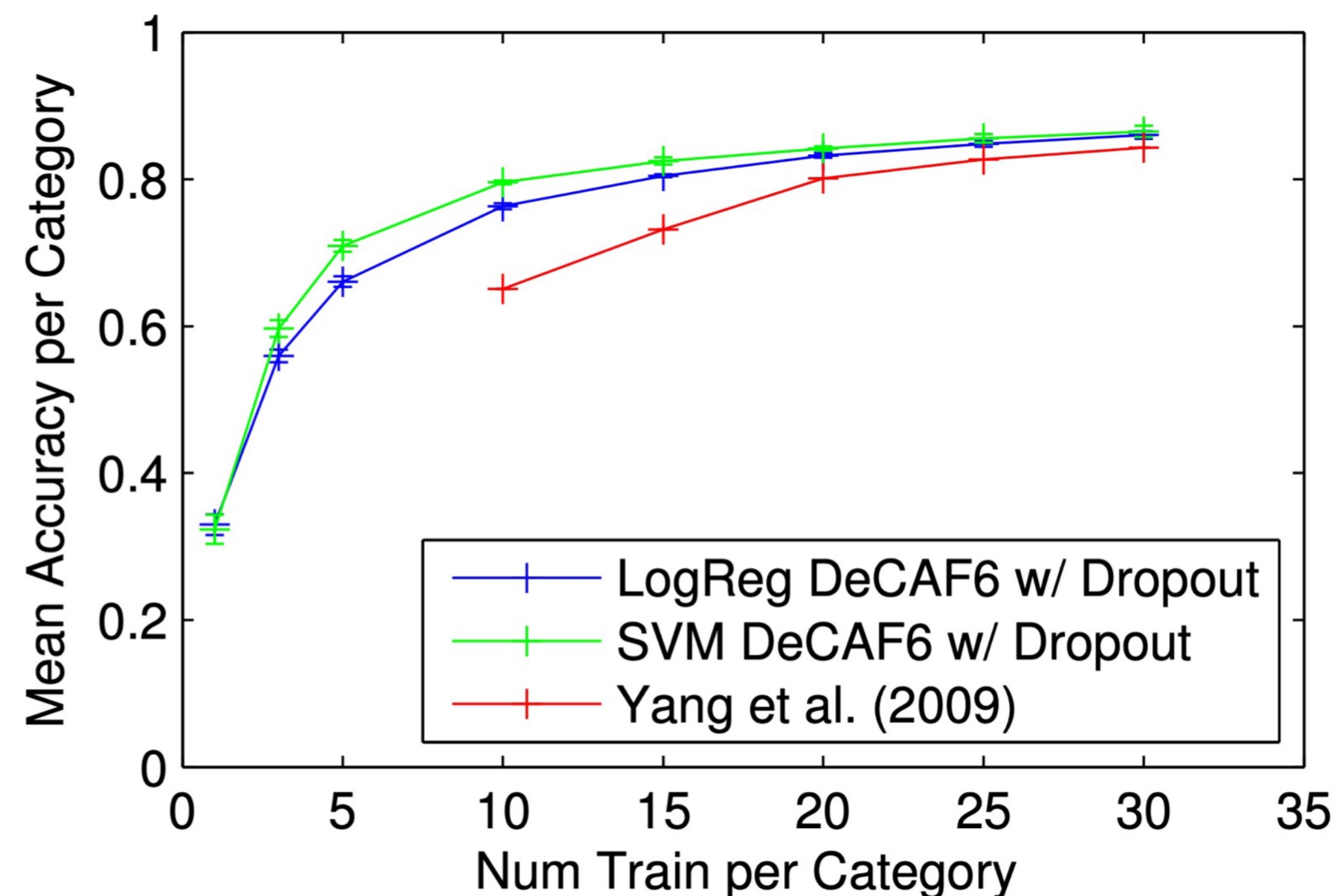





# Transfer Learning with CNNs

## 1. Train on ImageNet

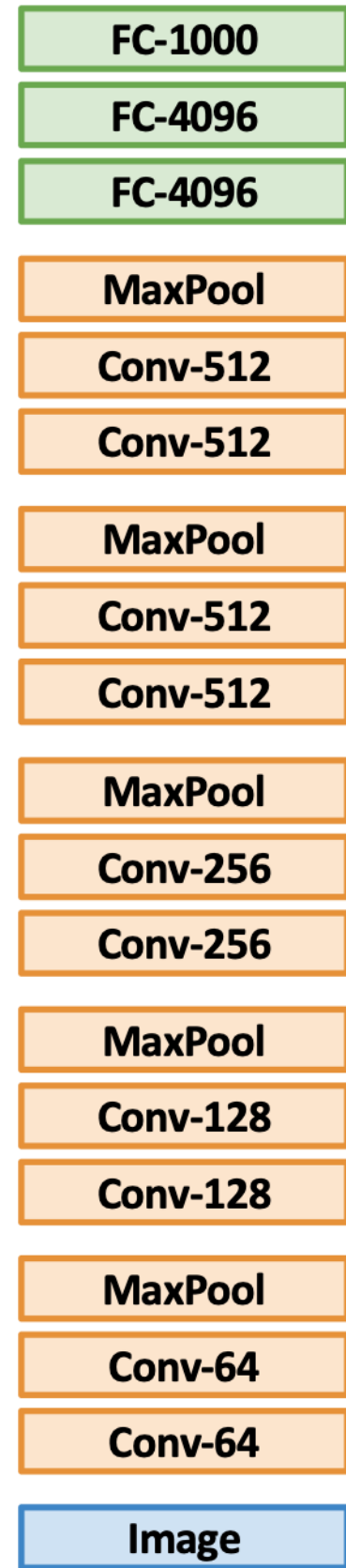

## 2. Use CNN as a feature extractor



Remove last layer

Freeze these

## Bird Classification on Caltech-UCSD

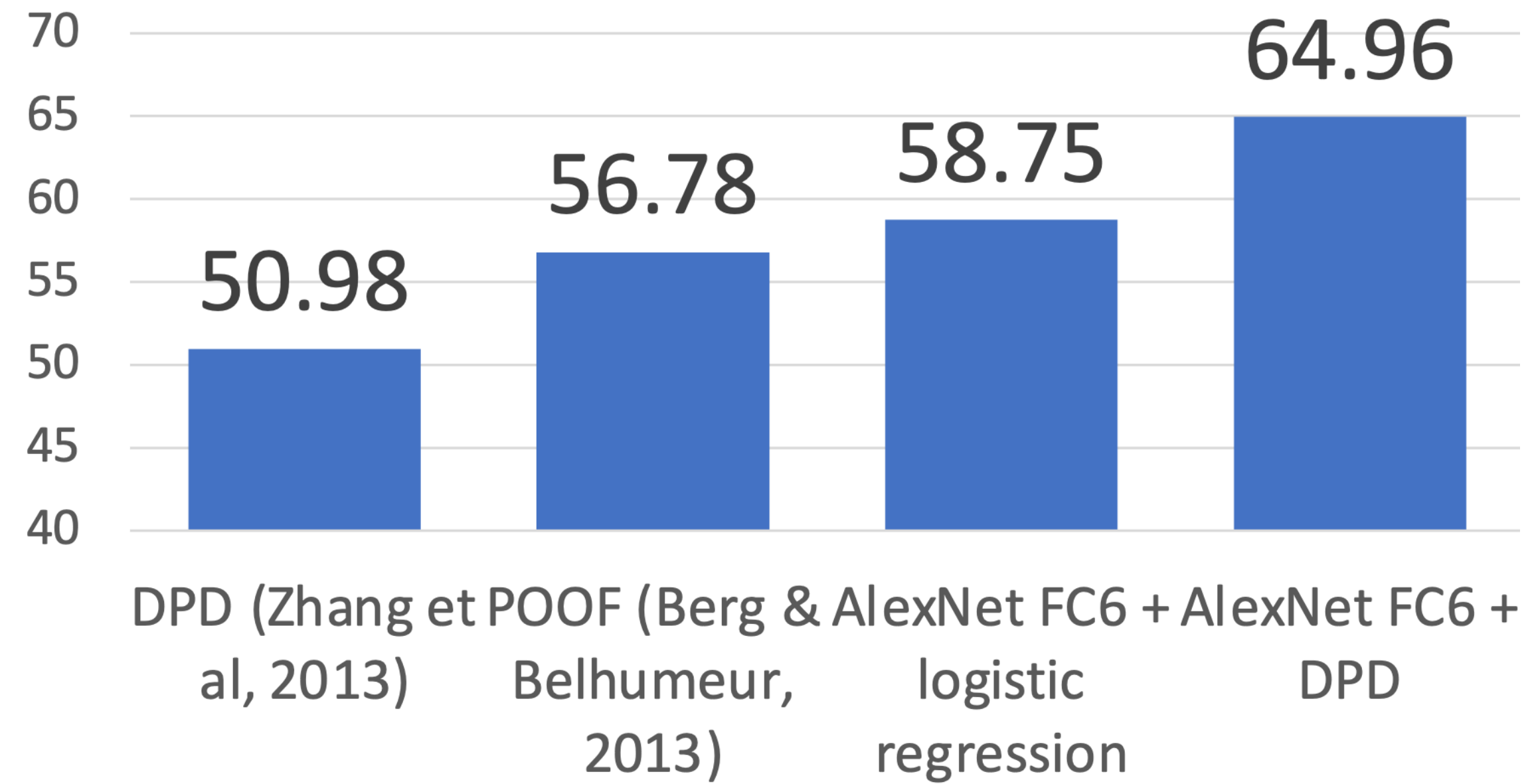



# Transfer Learning with CNNs

## 1. Train on ImageNet

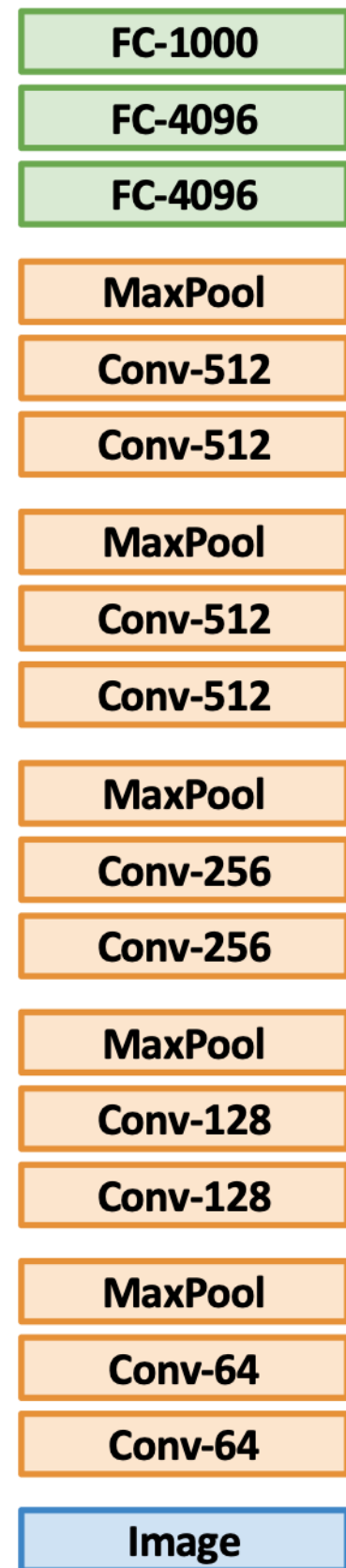

## 2. Use CNN as a feature extractor

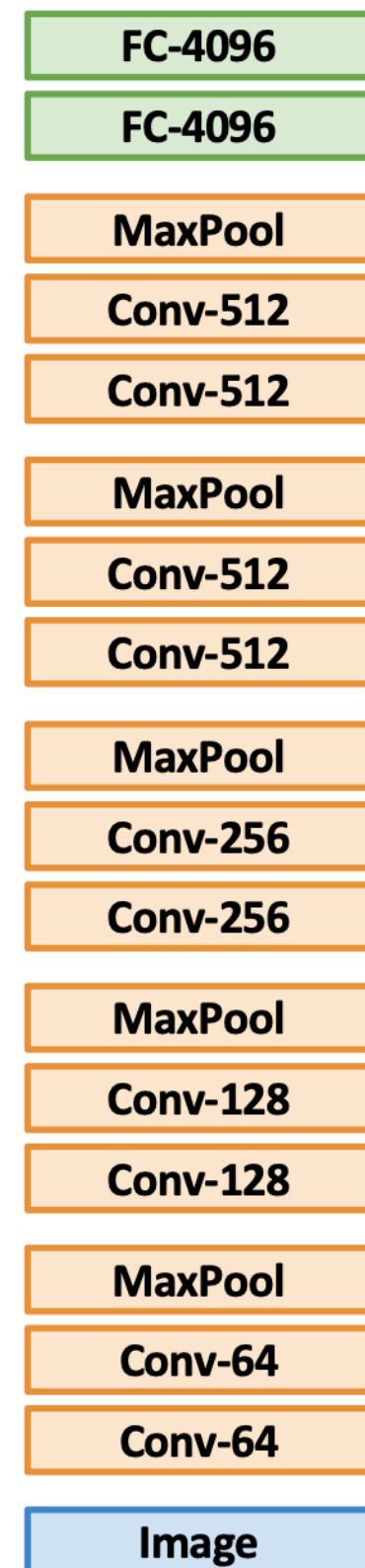

## Image Classification

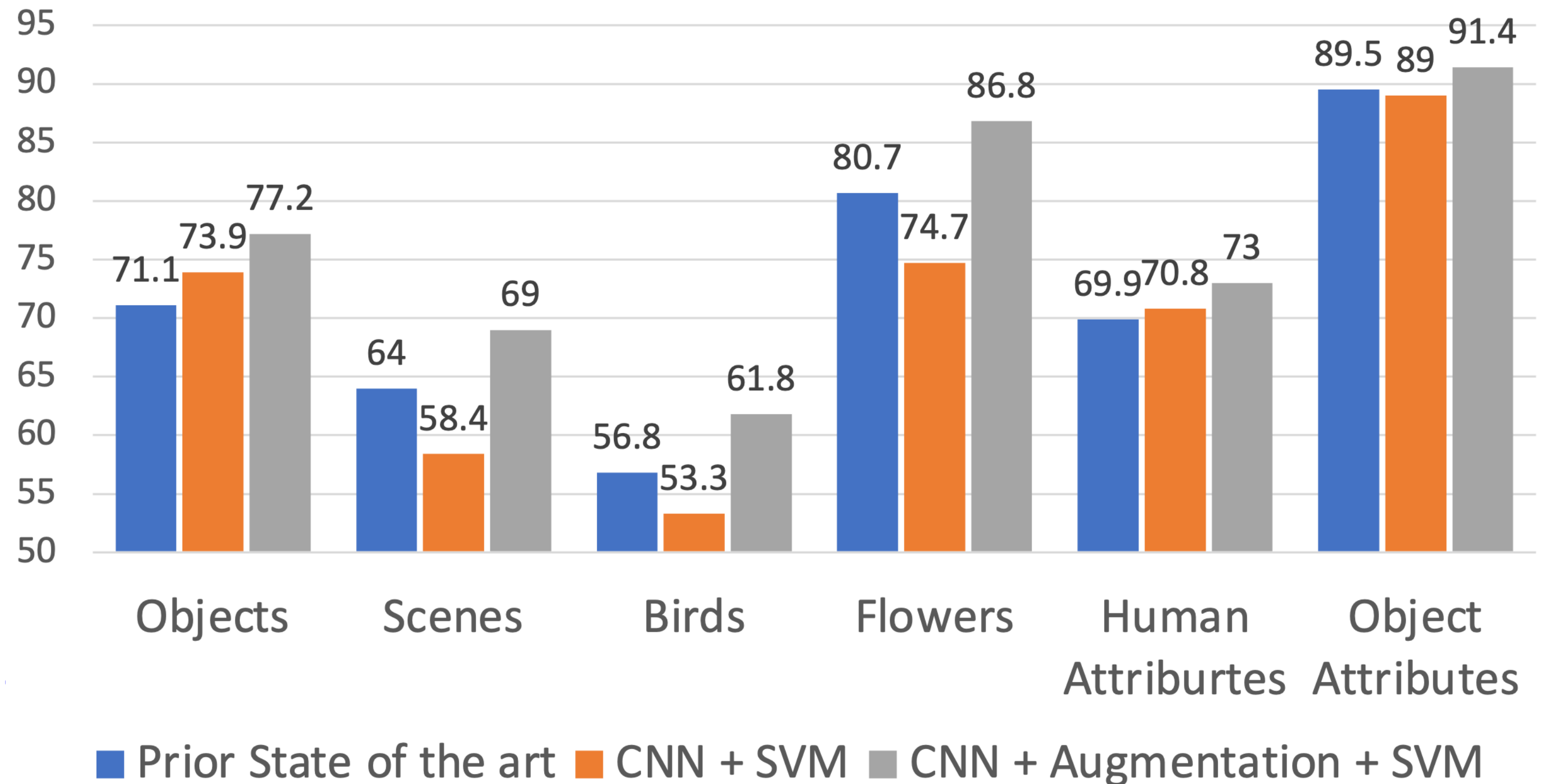



# Transfer Learning with CNNs

## 1. Train on ImageNet

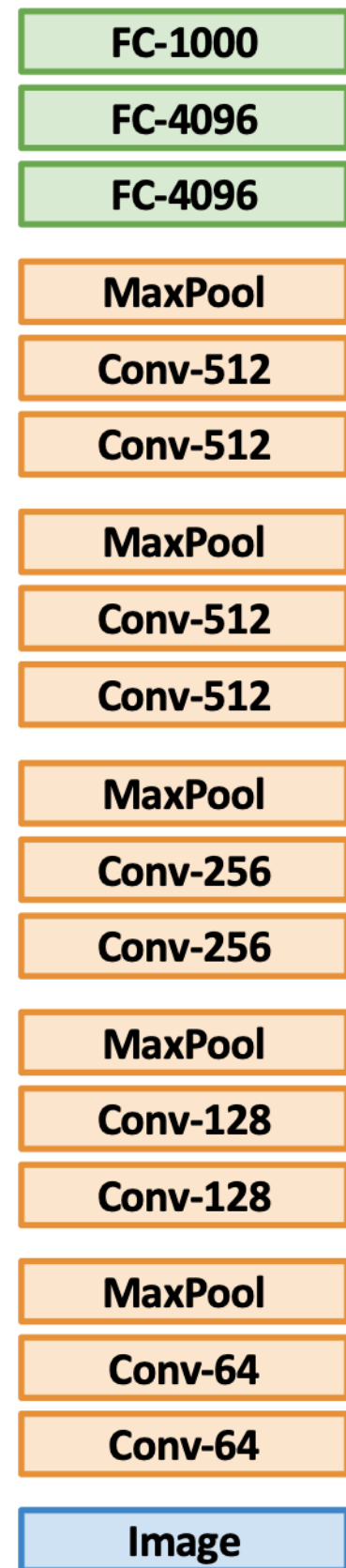

## 2. Use CNN as a feature extractor

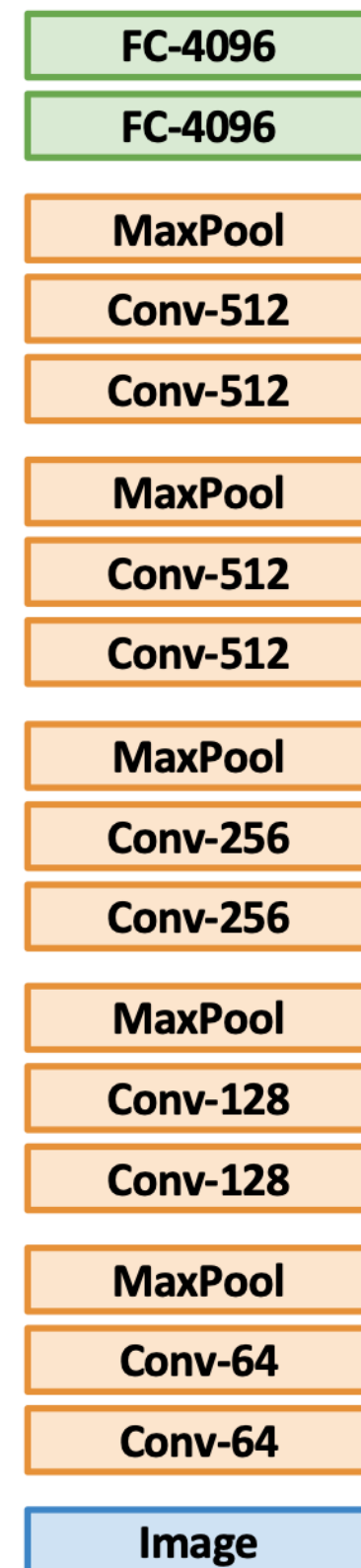

## Image Retrieval: Nearest-Neighbor

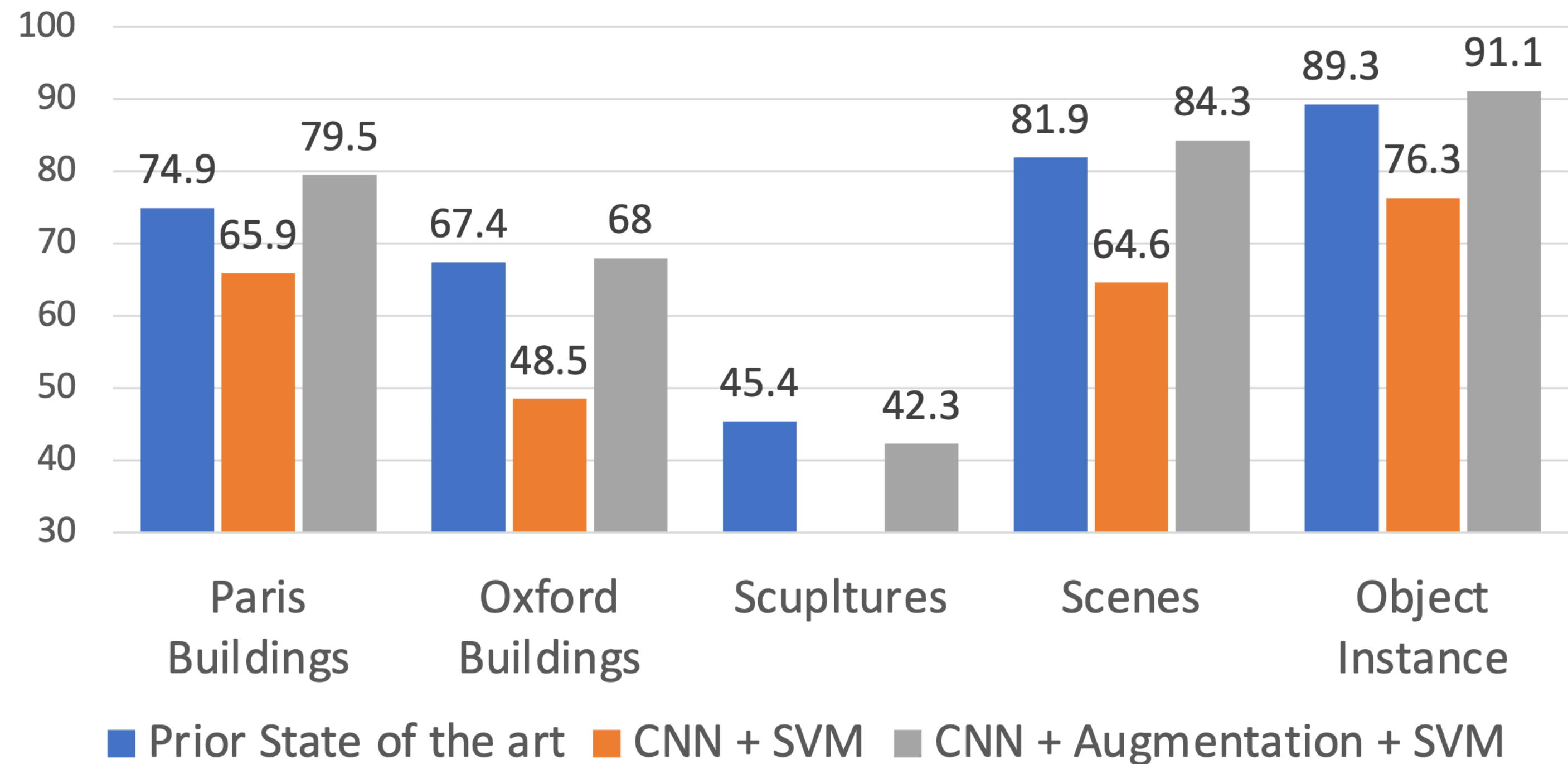



# Transfer Learning with CNNs

## 1. Train on ImageNet

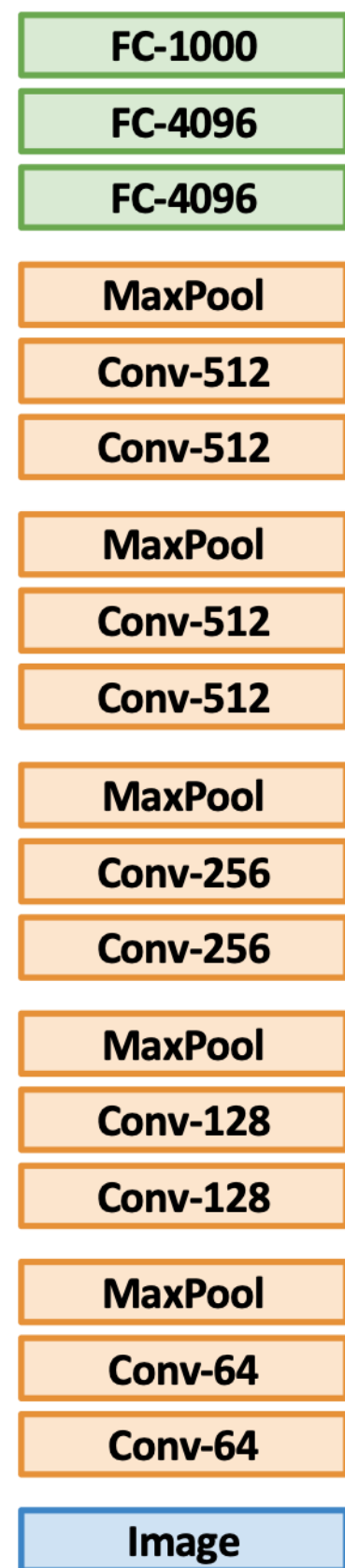

## 2. Use CNN as a feature extractor

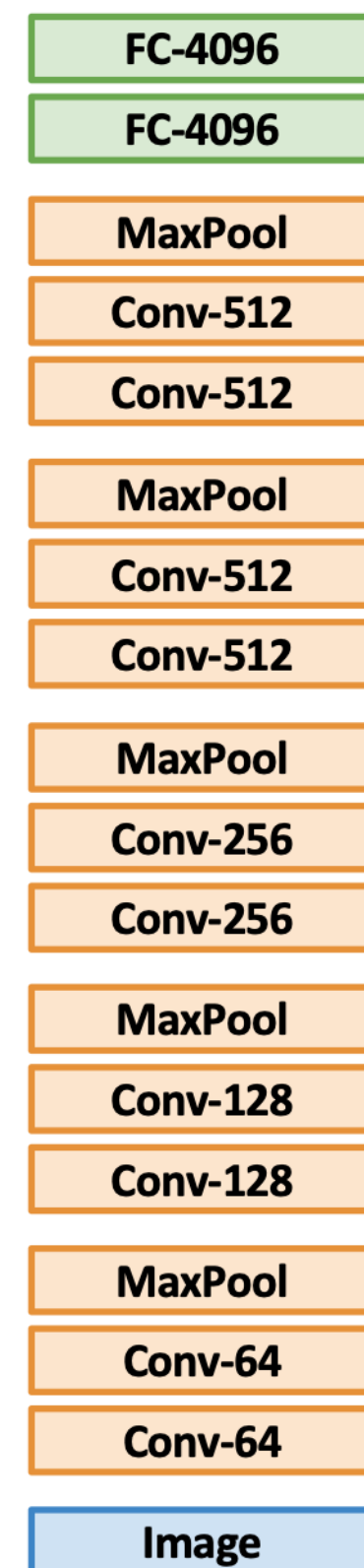

Remove last layer

Freeze these

## 3. Bigger dataset: Fine-Tuning

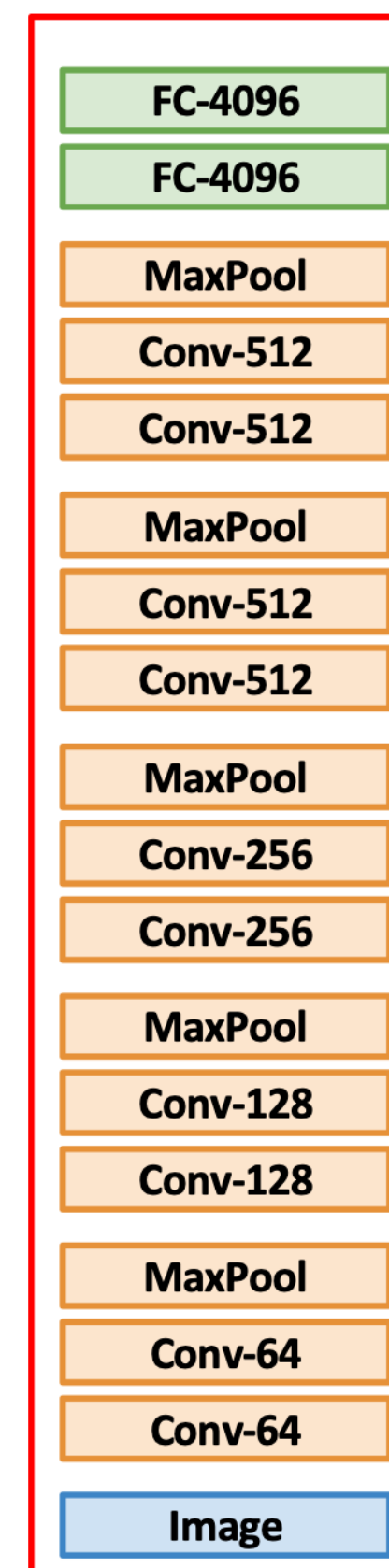

Continue training CNN for new task!



# Transfer Learning with CNNs

## 1. Train on ImageNet

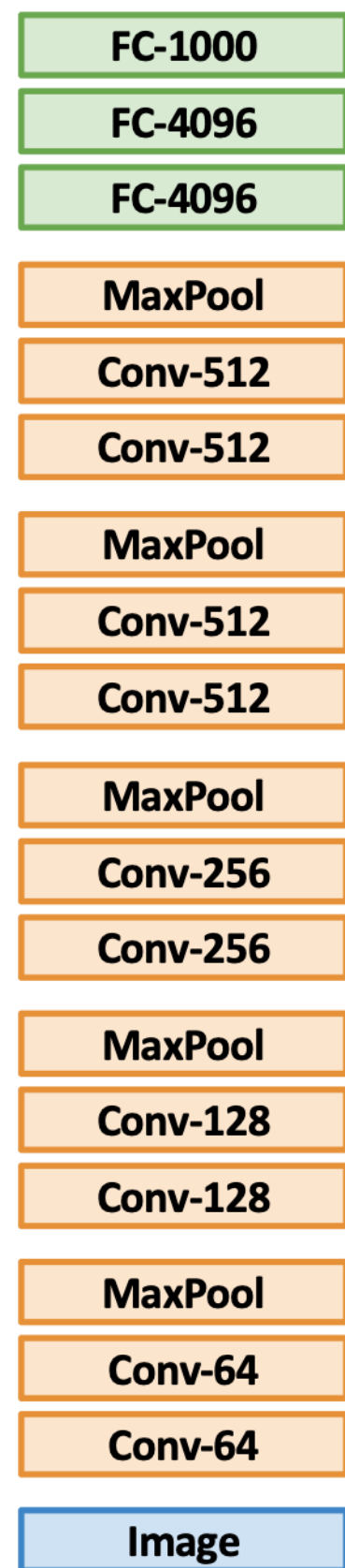

## 2. Use CNN as a feature extractor

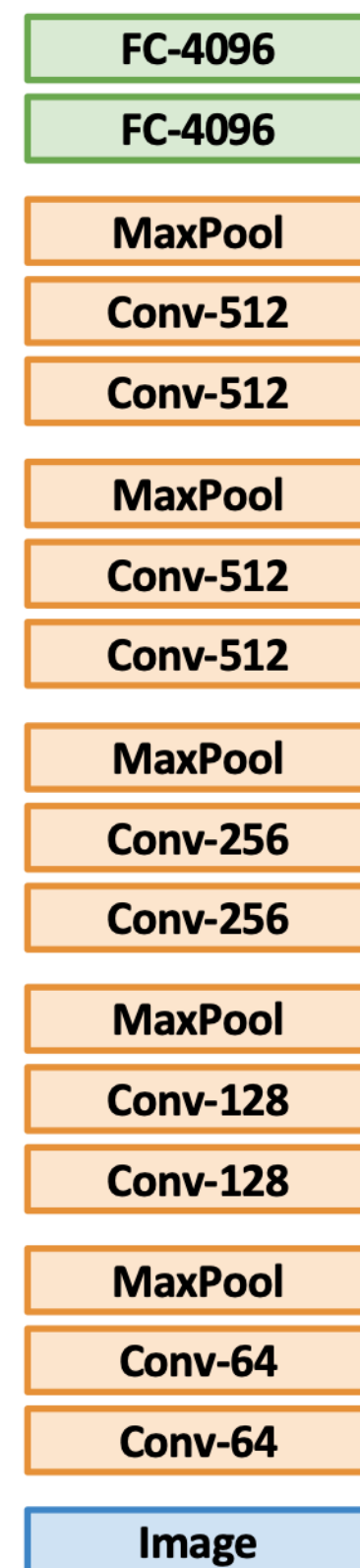

Remove last layer

Freeze these

## 3. Bigger dataset: Fine-Tuning

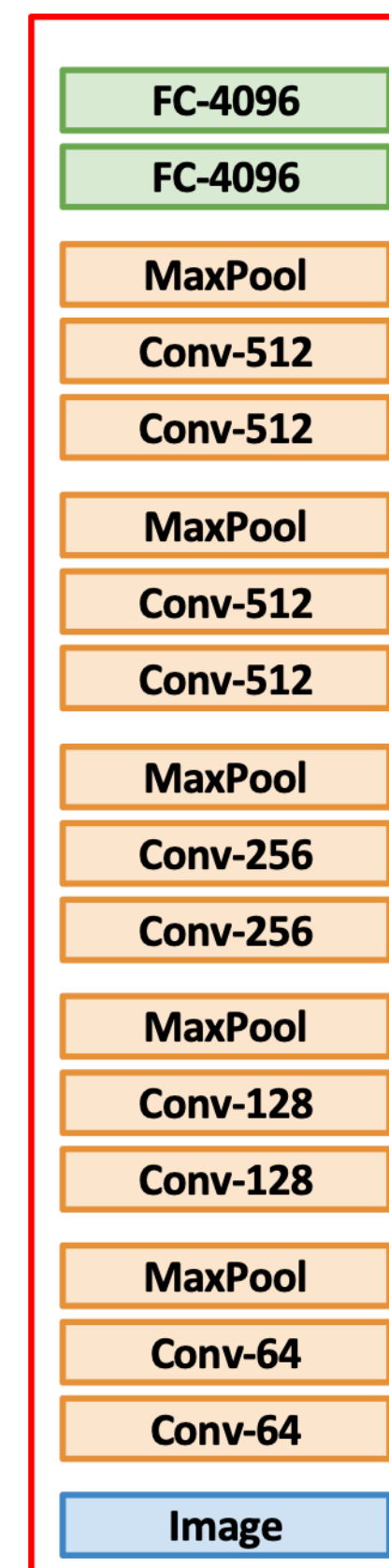

Continue training CNN for new task!

### Some tricks:

- Train with feature extraction first before fine-tuning
- Lower the learning rate: use  $\sim 1/10$  of LR used in original training
- Sometimes freeze lower layers to save computation
- Train with BatchNorm in “test” mode



# Transfer Learning with CNNs

## 1. Train on ImageNet

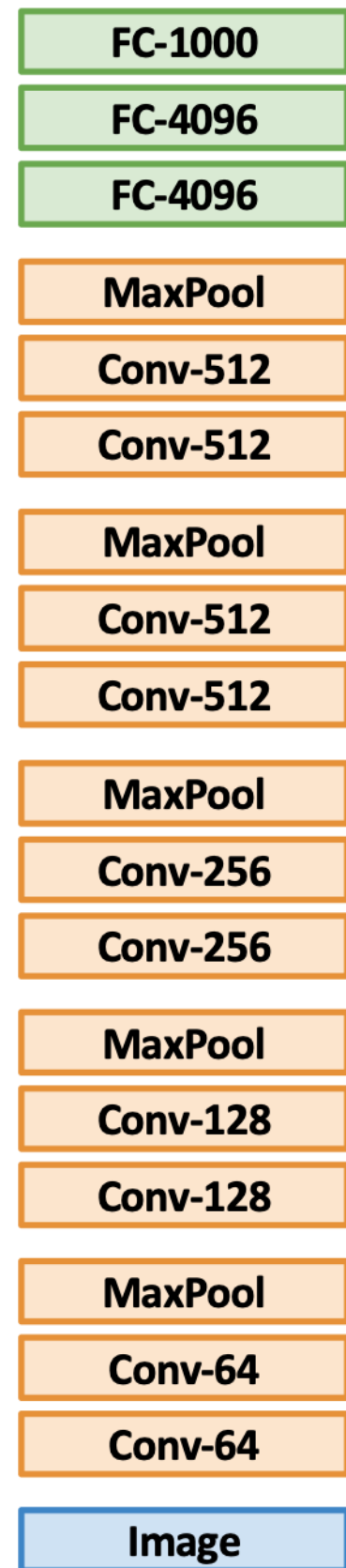

## 2. Use CNN as a feature extractor

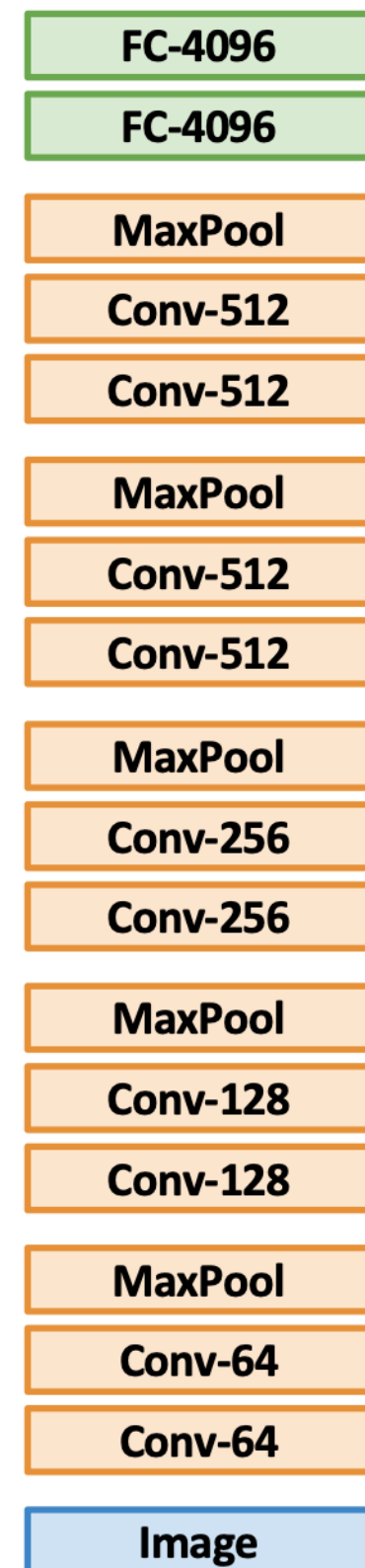

Remove last layer

Freeze these

## 3. Bigger dataset: Fine-Tuning

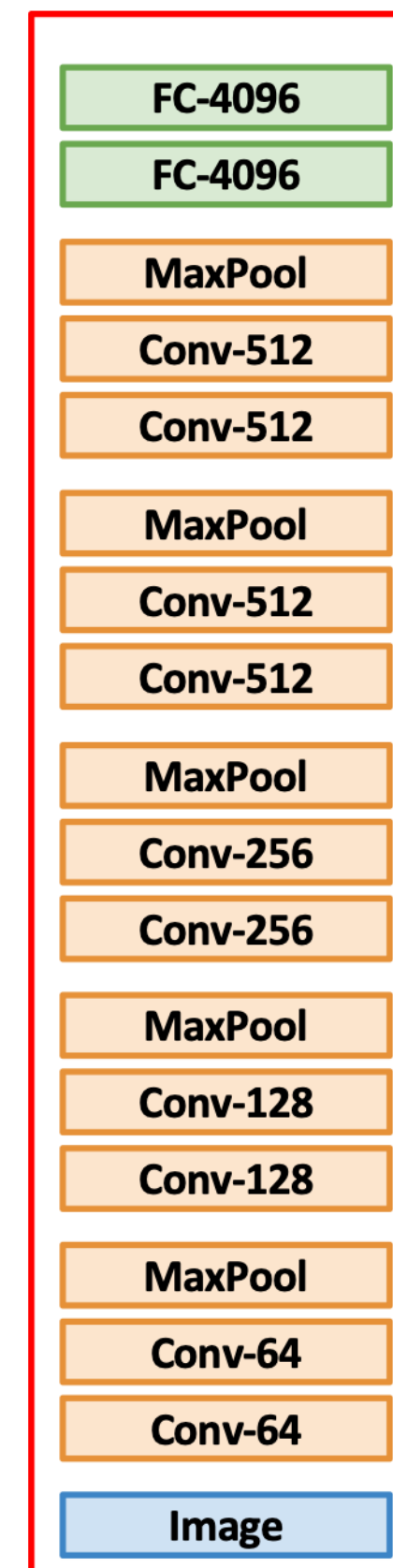

Continue training CNN for new task!

## Object Detection

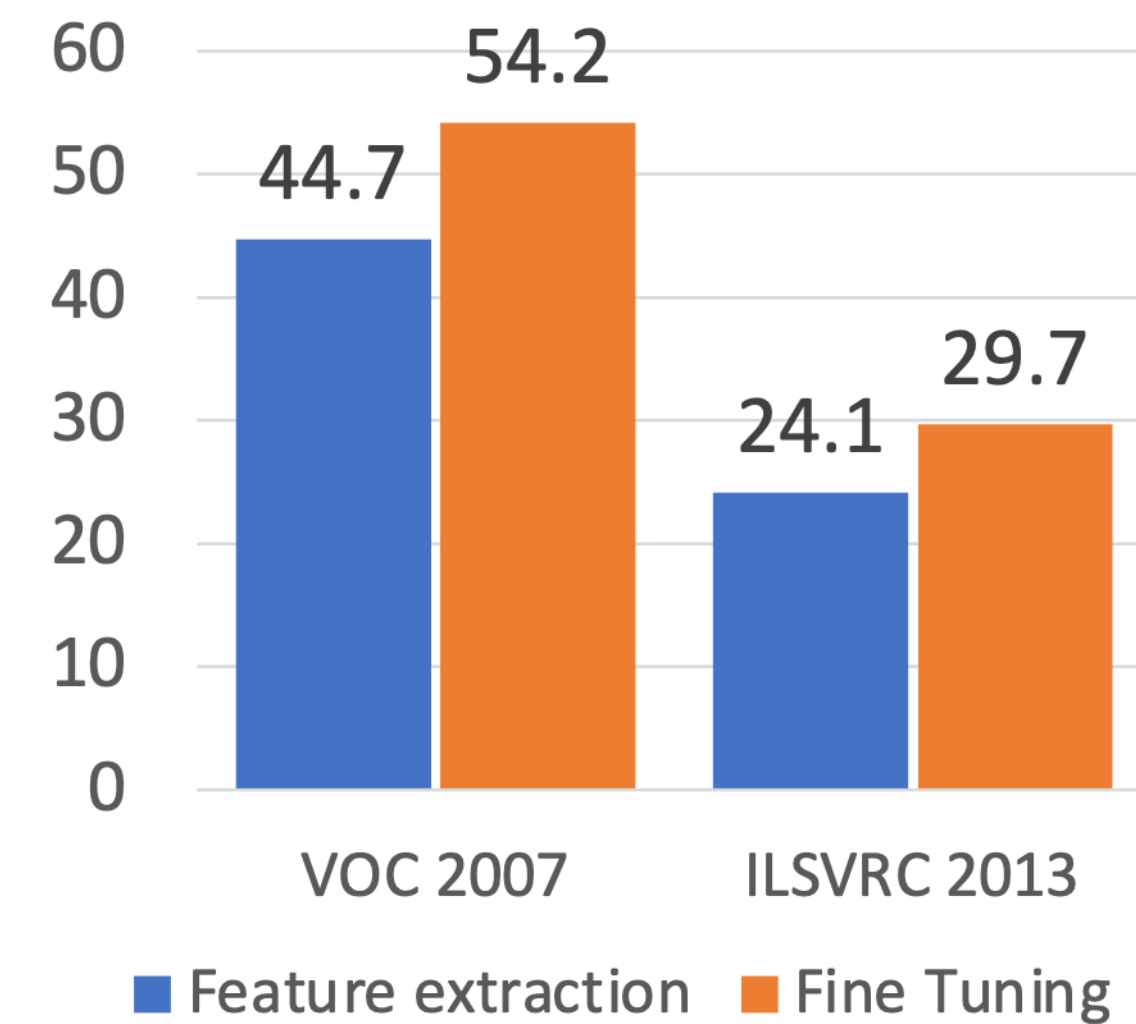



# Transfer Learning: Fine Tuning

## 1. Train on ImageNet

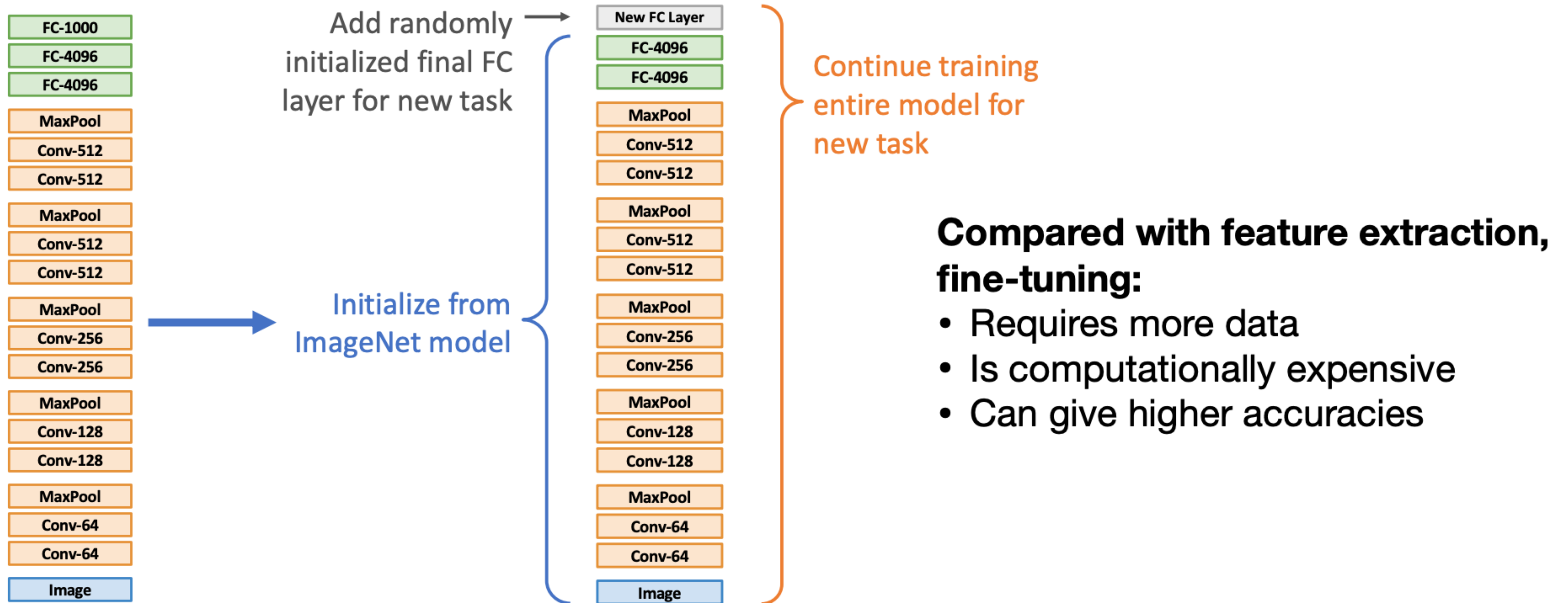



# Transfer Learning with CNNs: Architecture Matters!

## Object Detection on COCO

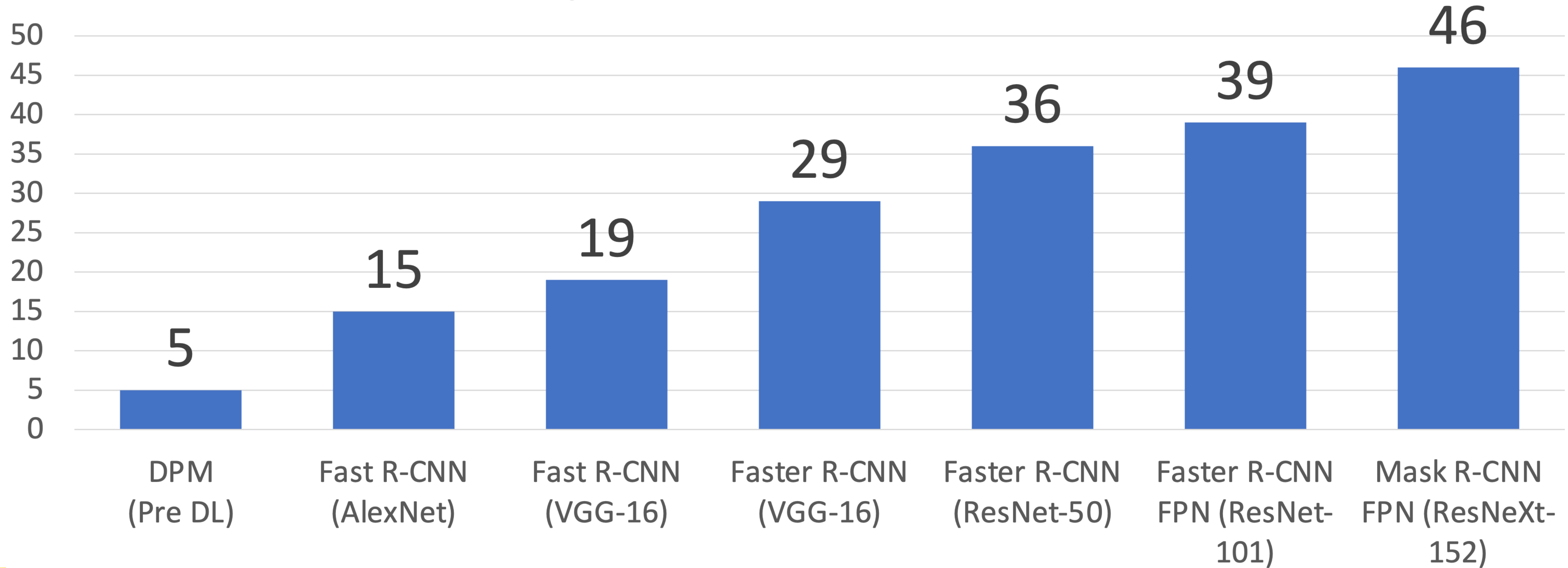





# Transfer Learning with CNNs



More specific

More generic

	Dataset similar to ImageNet	Dataset very different from ImageNet
Very little data (10s to 100s)	Use Linear Classifier on top layer	You're in trouble... Try linear classifier from different stages
Quite a lot of data (100s to 1000s)	Finetune a few layers	Finetune a larger number of layers



# Transfer Learning is pervasive! Its the norm, not the exception

## Object Detection (Fast R-CNN)

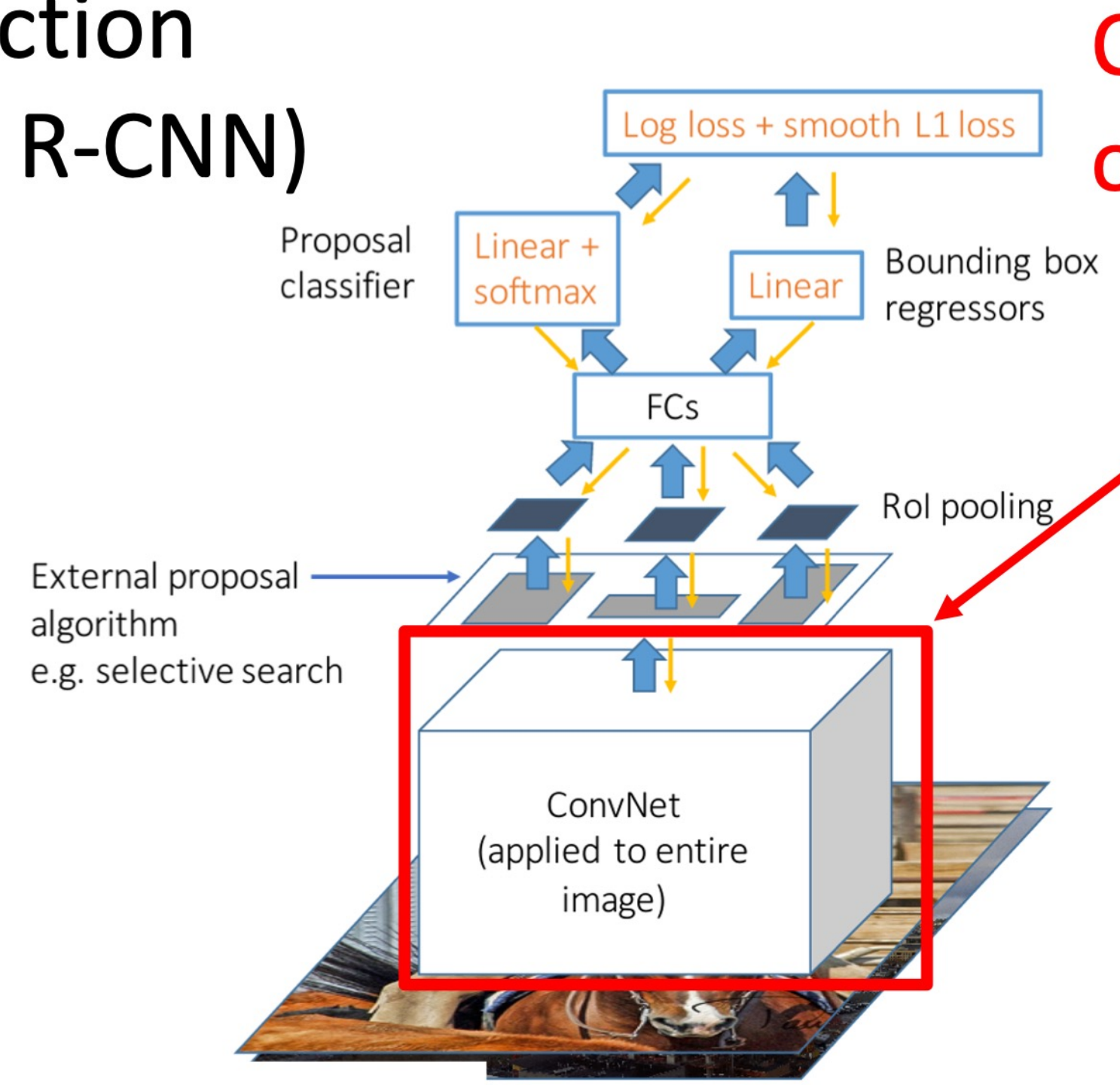

CNN pretrained on ImageNet

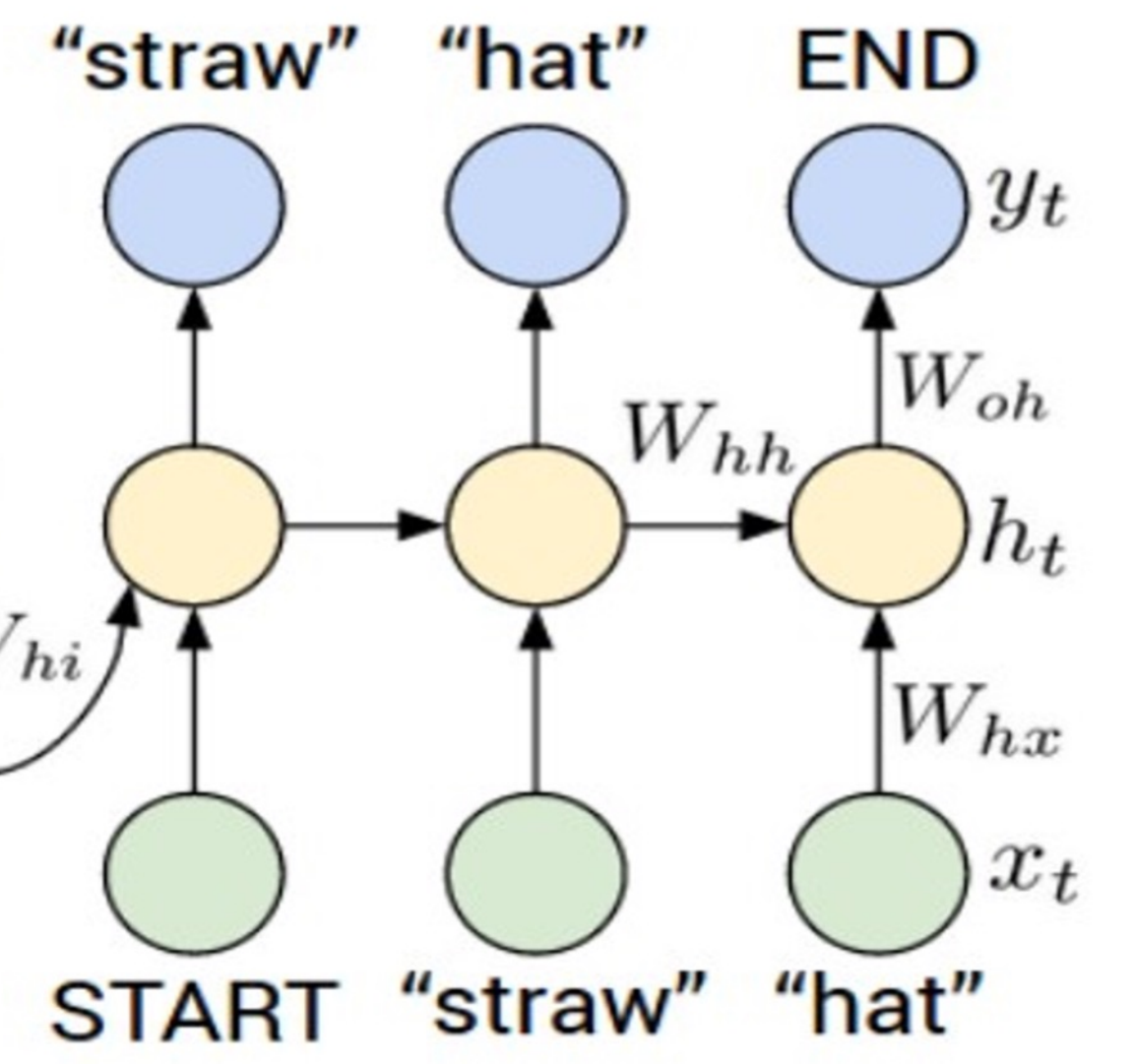
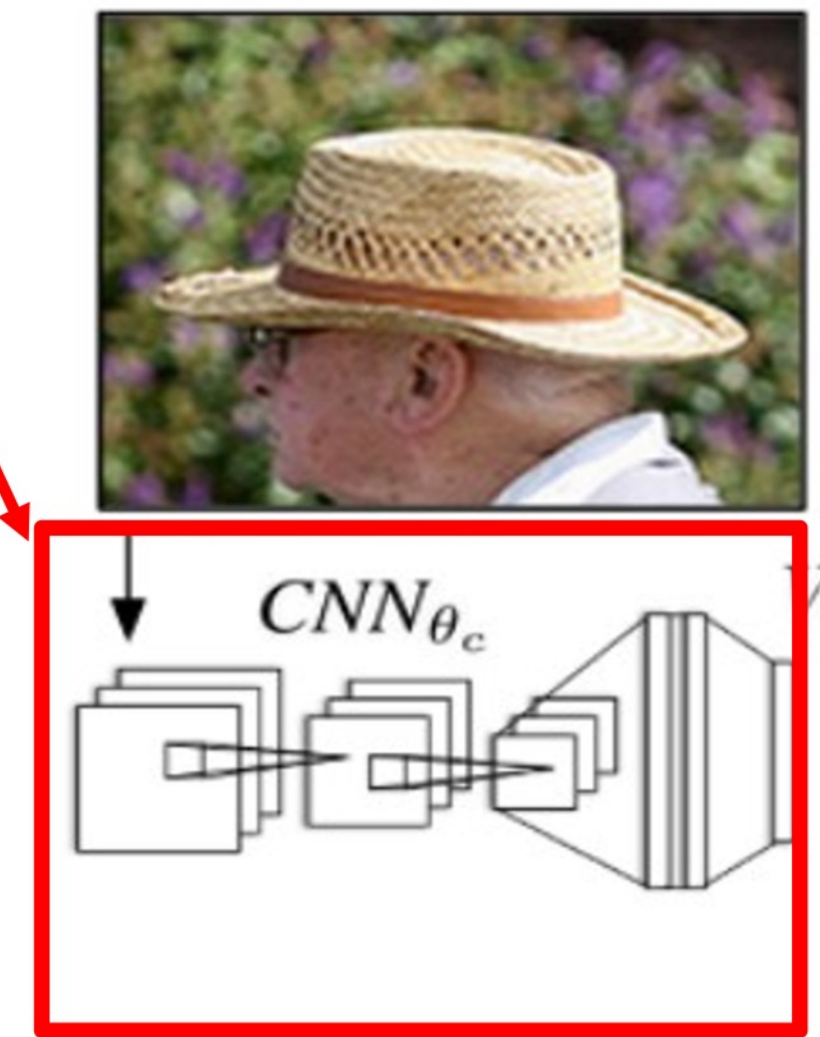

Girshick, "Fast R-CNN", ICCV 2015  
Figure copyright Ross Girshick, 2015. Reproduced with permission.

Karpathy and Fei-Fei, "Deep Visual-Semantic Alignments for Generating Image Descriptions", CVPR 2015





# Transfer Learning is pervasive! Its the norm, not the exception

## Object Detection (Fast R-CNN)

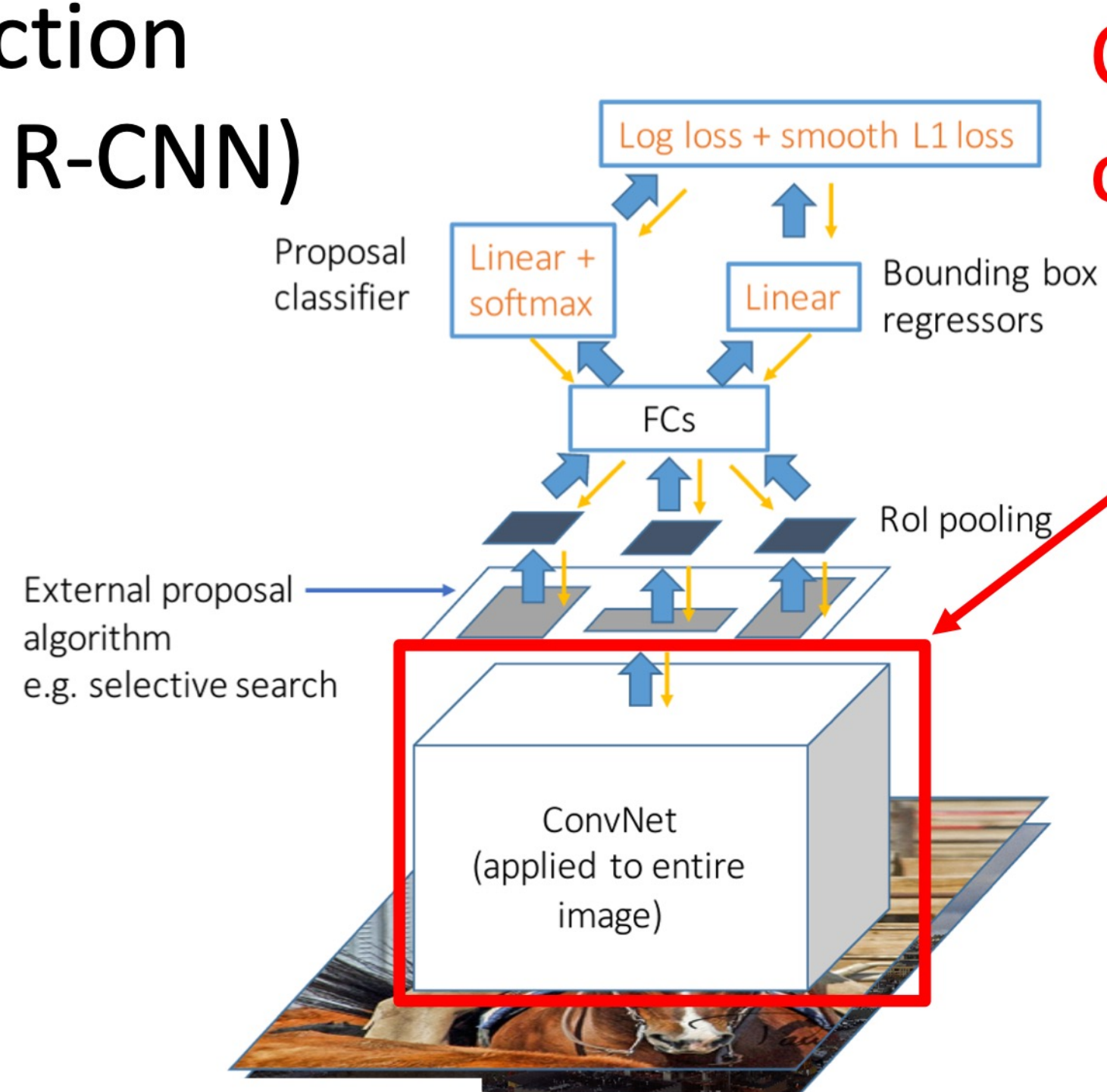

CNN pretrained on ImageNet

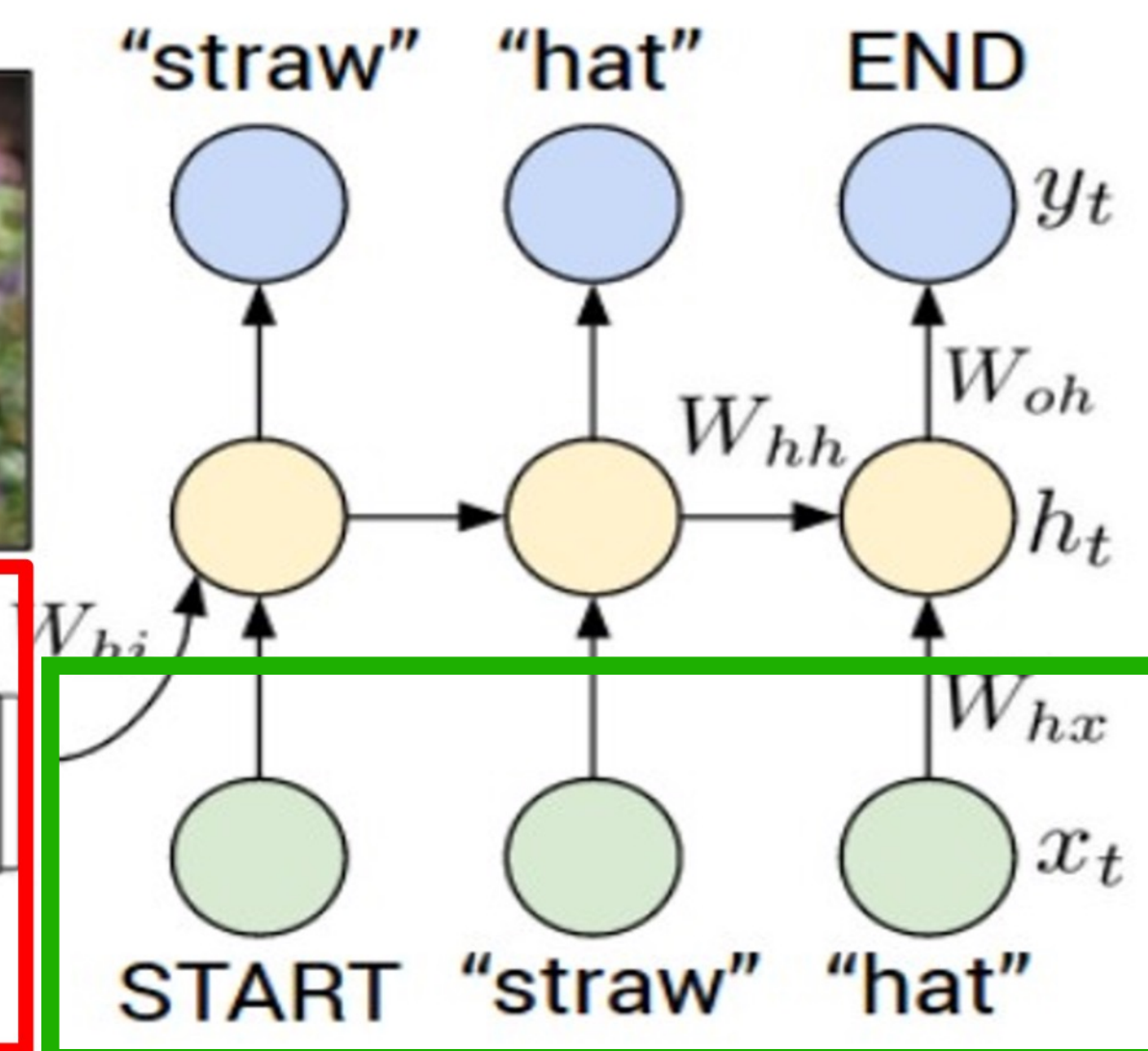
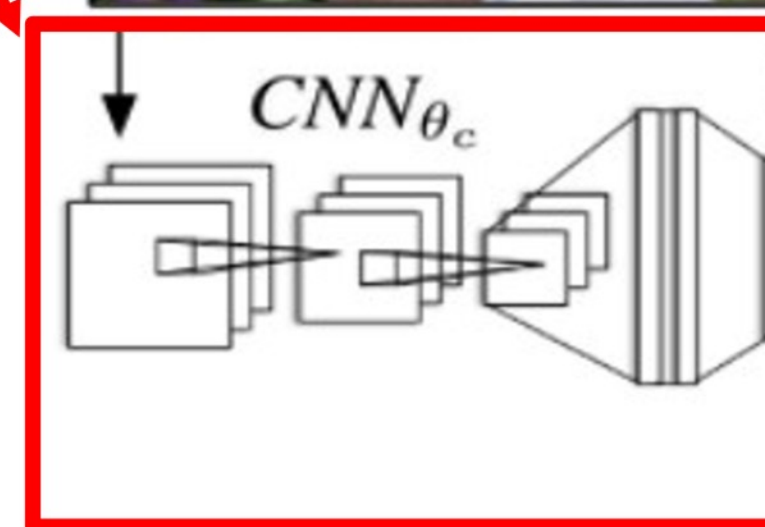

Word vectors pretrained with word2vec

Karpathy and Fei-Fei, "Deep Visual-Semantic Alignments for Generating Image Descriptions", CVPR 2015

Girshick, "Fast R-CNN", ICCV 2015  
Figure copyright Ross Girshick, 2015. Reproduced with permission.



# Transfer Learning is pervasive! Its the norm, not the exception

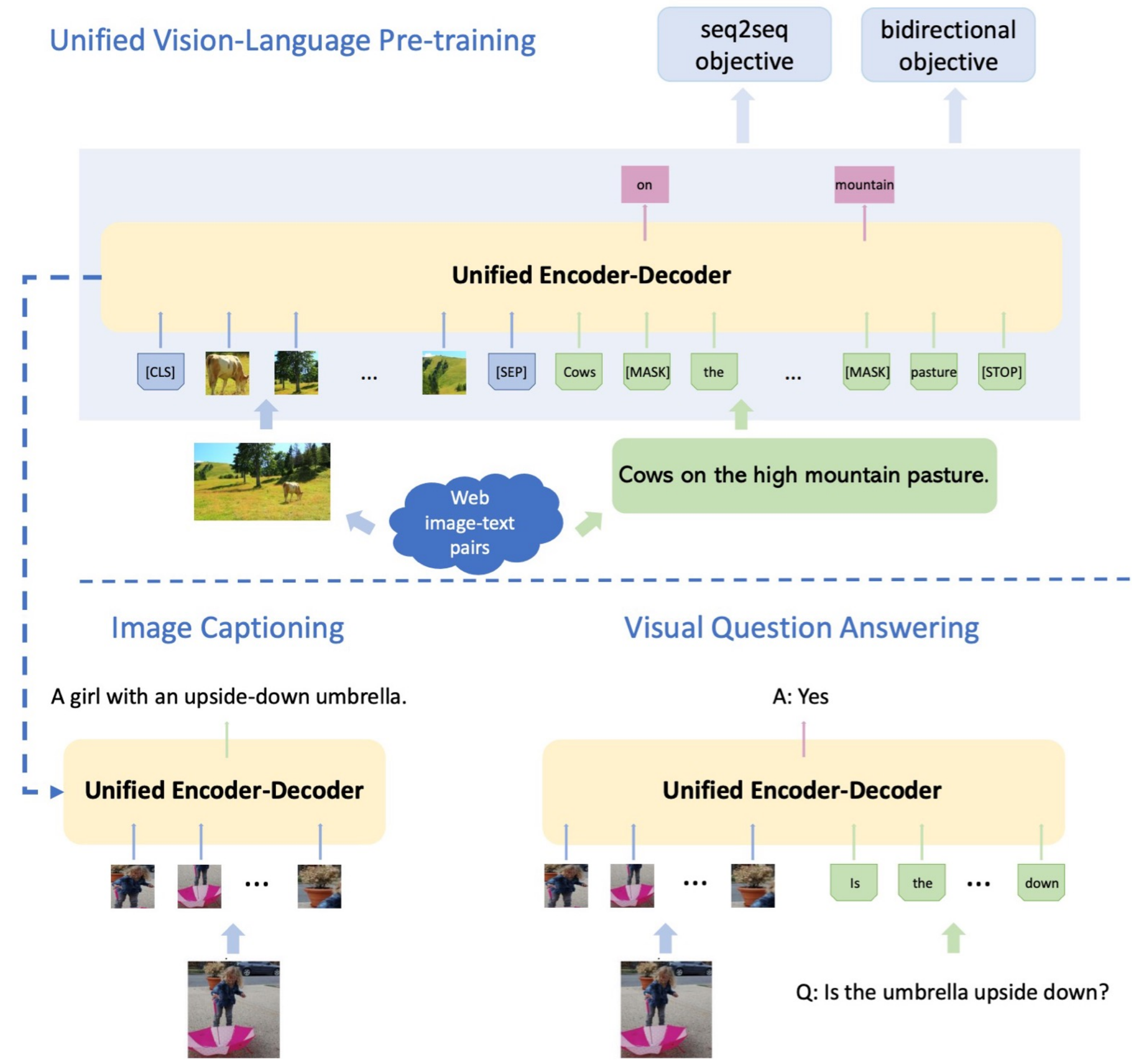

1. Train CNN on ImageNet
2. Fine-Tune (1) for object detection on Visual Genome
3. Train BERT language model on lots of text
4. Combine (2) and (3), train for joint image / language modeling
5. Fine-tune (5) for image captioning, visual question answering, etc.



# Transfer Learning is pervasive!

## Some very recent results have questioned it

### COCO object detection

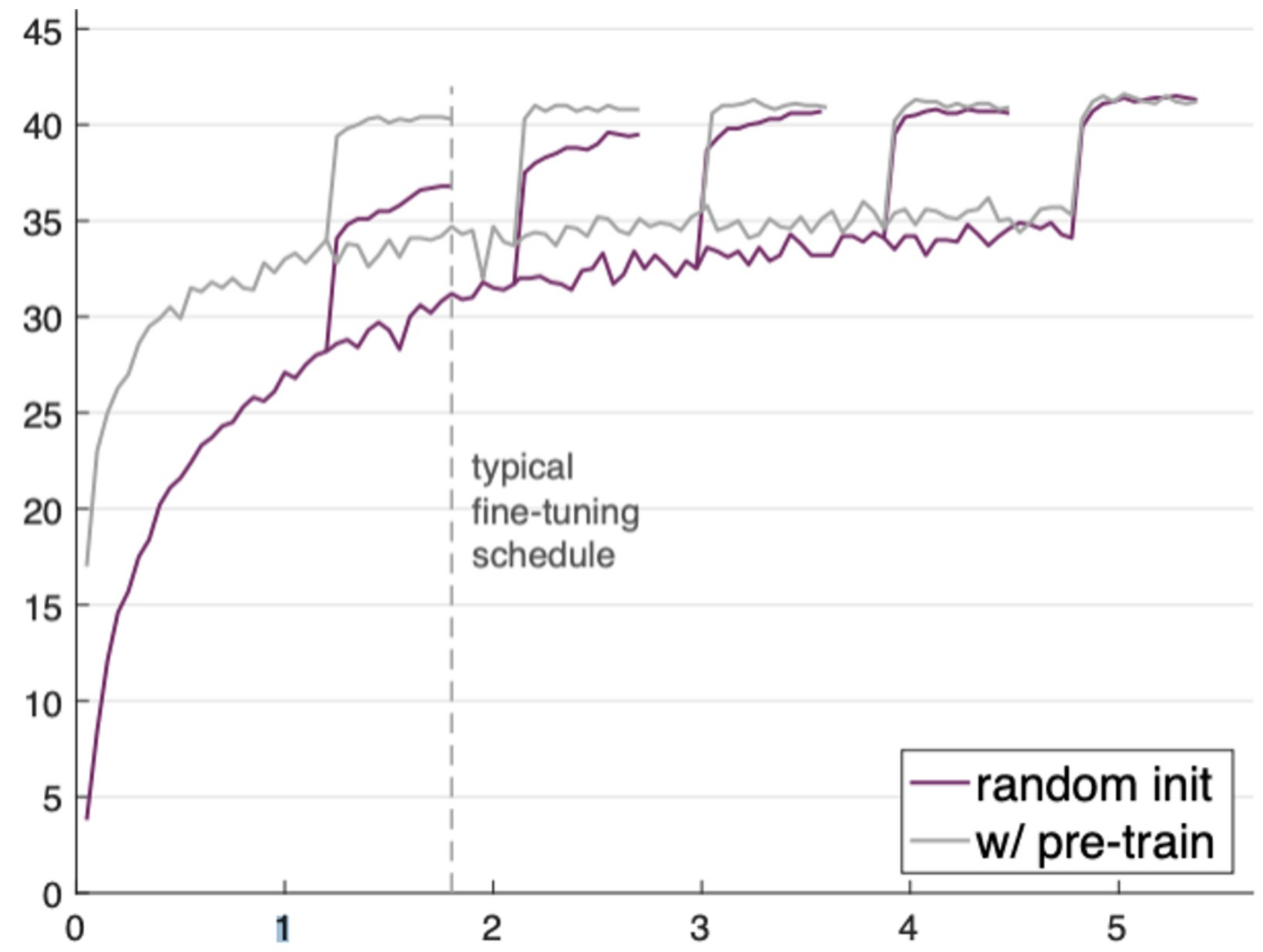

Training from scratch can work as well as pertaining on ImageNet!

... if you train for 3x as long

He et al, "Rethinking ImageNet Pre-Training", ICCV 2019





# Transfer Learning is pervasive!

## Some very recent results have questioned it

### COCO object detection

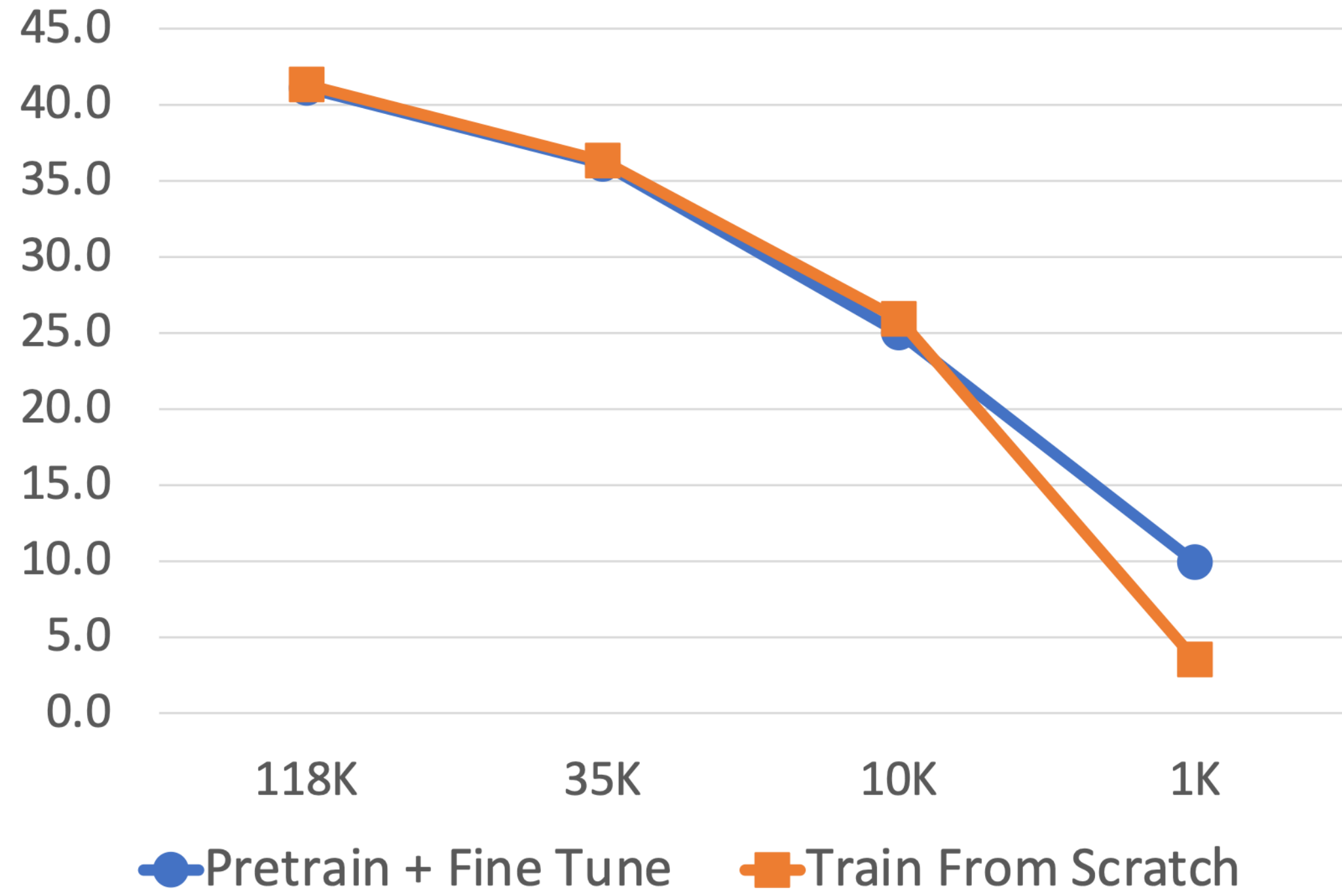

Pretraining + Finetuning beats training from scratch when dataset size is very small

Collecting more data is more effective than pretraining

He et al, "Rethinking ImageNet Pre-Training", ICCV 2019





# Transfer Learning is pervasive!

## Some very recent results have questioned it

### COCO object detection

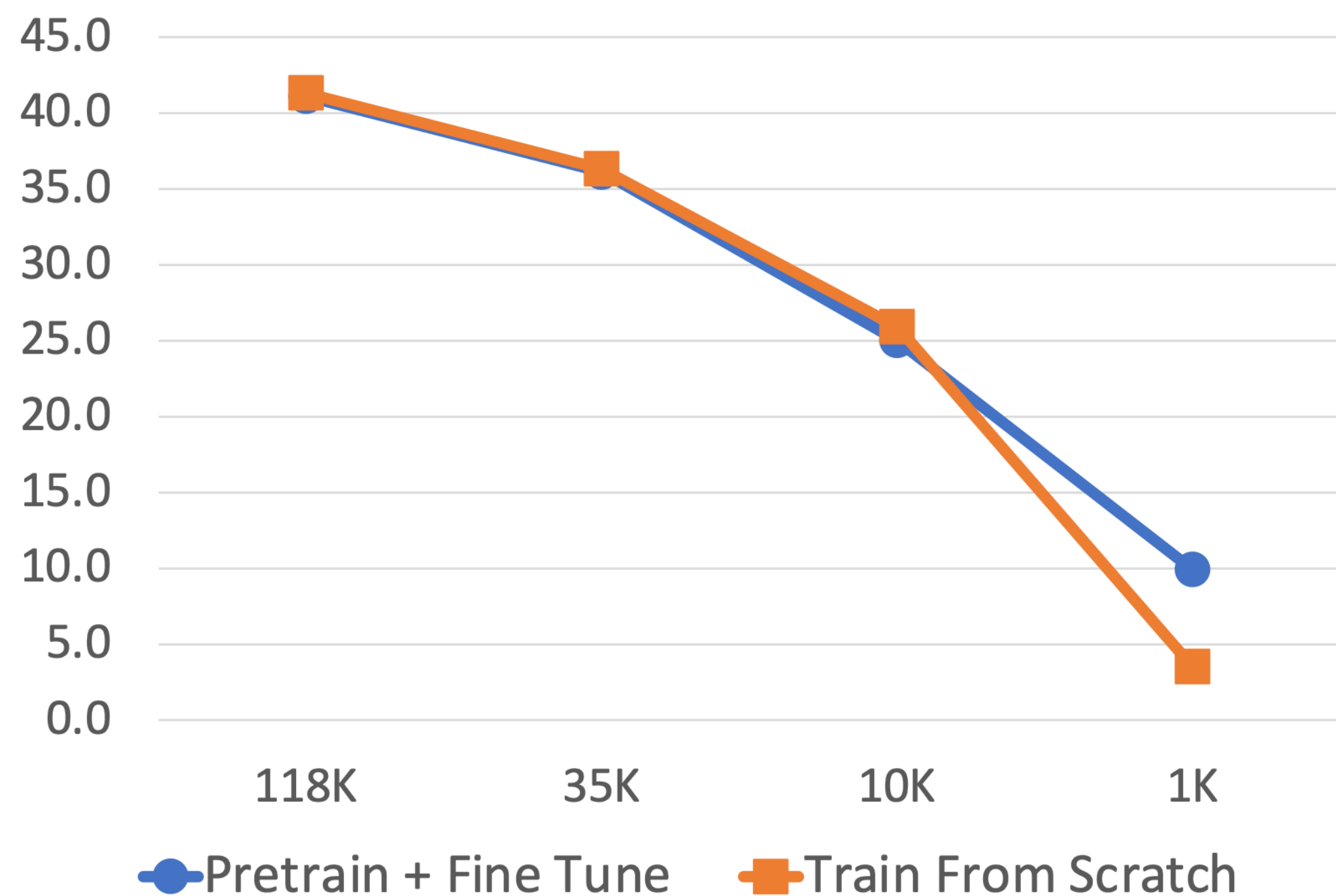

My current view on transfer learning:

- Pretrain + finetune makes your training faster, so practically very useful
- Training from scratch works well once you have enough data
- Lots of work left to be done

He et al, "Rethinking ImageNet Pre-Training", ICCV 2019



# Summary

## 1. One time setup:

- Activation functions, data preprocessing, weight initialization, regularization

## 2. Training dynamics:

- Learning rate schedules; hyperparameter optimization

## 3. After training:

- Model ensembles, transfer learning





# A zoo of frameworks!

Caffe  
(UC Berkeley)



Caffe2  
(Facebook)

Torch  
(NYU / Facebook)



PyTorch  
(Facebook)

Theano  
(U Montreal)



TensorFlow  
(Google)

Darknet  
(Redmon)

MXNet

(Amazon)

Developed by U Washington, CMU, MIT, Hong Kong U, etc. but main framework of choice at AWS

PaddlePaddle  
(Baidu)

Chainer

CNTK

(Microsoft)

JAX

(Google)



# A zoo of frameworks!

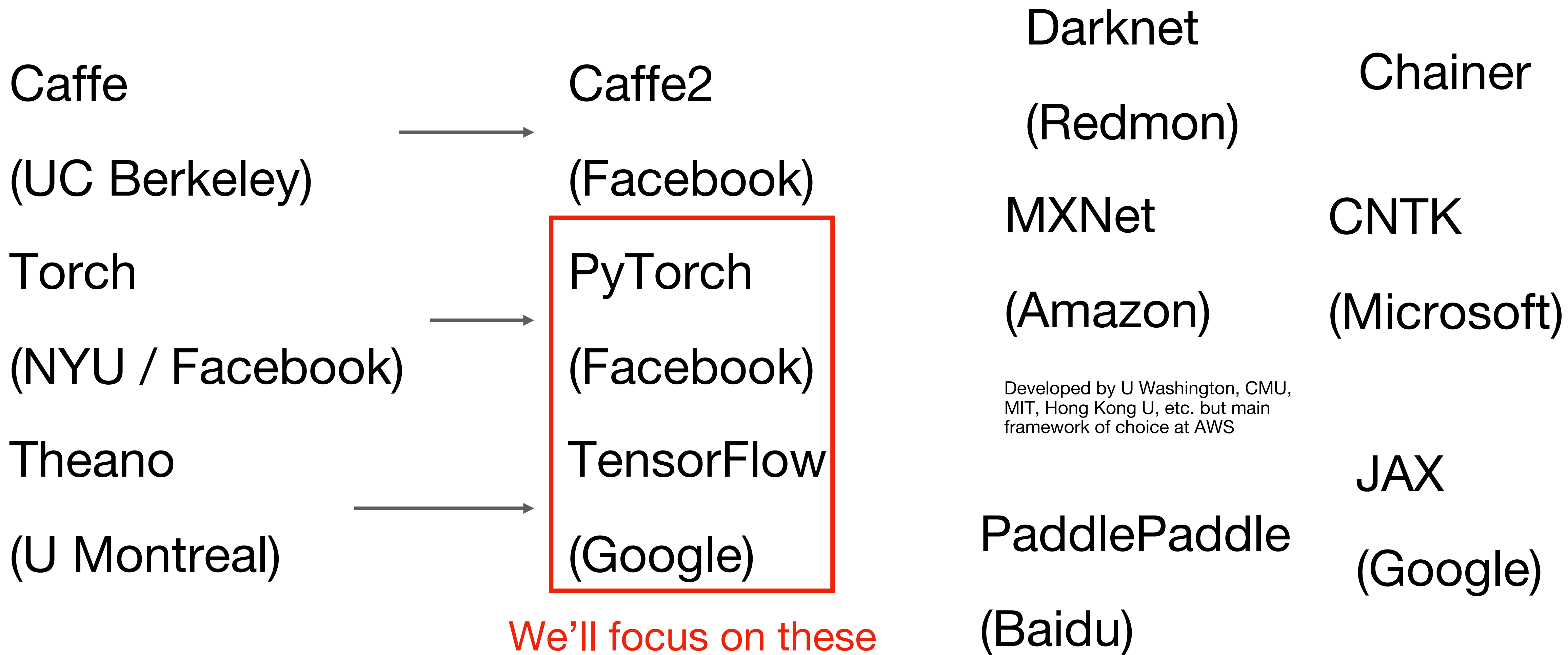

We'll focus on these



# Recall: Computational Graphs

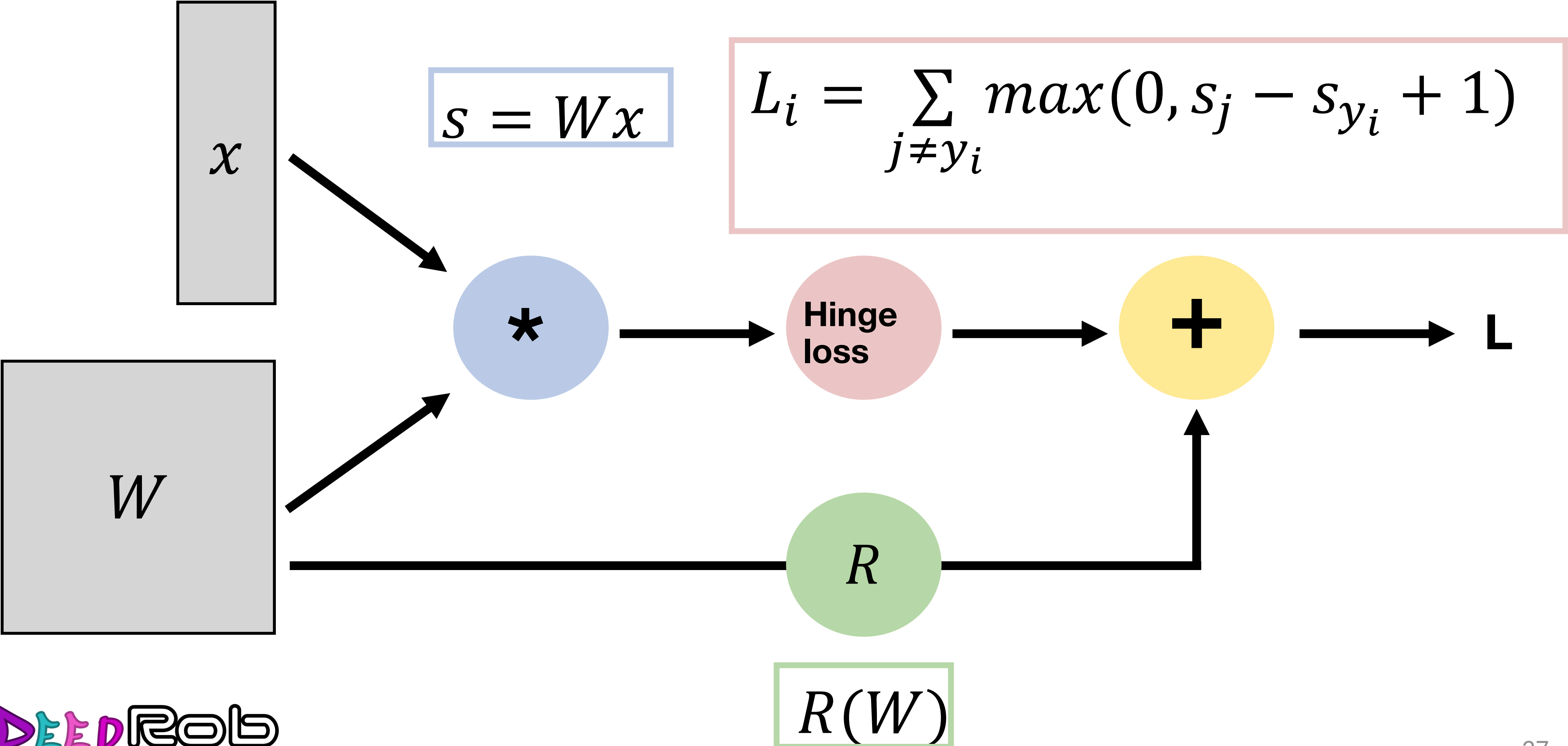



# The motivation for deep learning frameworks

---

1. Allow rapid prototyping of new ideas
2. Automatically compute gradients for you
3. Run it all efficiently on GPU or TPU hardware



# PyTorch: Versions

---

For this class we are using **PyTorch version 1.13**  
(Released October 2022)

Be careful if you are looking at older PyTorch code—  
the API changed a lot before 1.0



# PyTorch: Version 2.2 (2024)

---

further optimize models (`torch.compile`,  
`scaled_dot_product_attention`)

Intended (not committing) to be backwards compatible



Video credit: [PyTorch](#)



# PyTorch: Fundamental Concepts

---

**Tensor:** Like a numpy array, but can run on GPU

**Autograd:** Package for building computational graphs out of Tensors, and automatically computing gradients

**Module:** A neural network layer; may store state or learnable weights



# PyTorch: Tensors

Running example:  
Train a two-layer ReLU network  
on random data with L2 loss

```
import torch

device = torch.device('cpu')

N, D_in, H, D_out = 64, 1000, 100, 10
x = torch.randn(N, D_in, device=device)
y = torch.randn(N, D_out, device=device)
w1 = torch.randn(D_in, H, device=device)
w2 = torch.randn(H, D_out, device=device)

learning_rate = 1e-6
for t in range(500):
    h = x.mm(w1)
    h_relu = h.clamp(min=0)
    y_pred = h_relu.mm(w2)
    loss = (y_pred - y).pow(2).sum()

    grad_y_pred = 2.0 * (y_pred - y)
    grad_w2 = h_relu.t().mm(grad_y_pred)
    grad_h_relu = grad_y_pred.mm(w2.t())
    grad_h = grad_h_relu.clone()
    grad_h[h < 0] = 0
    grad_w1 = x.t().mm(grad_h)

    w1 -= learning_rate * grad_w1
    w2 -= learning_rate * grad_w2
```





# PyTorch: Tensors

Create random tensors  
for data and weights



```
import torch

device = torch.device('cpu')

N, D_in, H, D_out = 64, 1000, 100, 10
x = torch.randn(N, D_in, device=device)
y = torch.randn(N, D_out, device=device)
w1 = torch.randn(D_in, H, device=device)
w2 = torch.randn(H, D_out, device=device)

learning_rate = 1e-6
for t in range(500):
    h = x.mm(w1)
    h_relu = h.clamp(min=0)
    y_pred = h_relu.mm(w2)
    loss = (y_pred - y).pow(2).sum()

    grad_y_pred = 2.0 * (y_pred - y)
    grad_w2 = h_relu.t().mm(grad_y_pred)
    grad_h_relu = grad_y_pred.mm(w2.t())
    grad_h = grad_h_relu.clone()
    grad_h[h < 0] = 0
    grad_w1 = x.t().mm(grad_h)

    w1 -= learning_rate * grad_w1
    w2 -= learning_rate * grad_w2
```



# PyTorch: Tensors

Forward pass: compute predictions and loss



```
import torch

device = torch.device('cpu')

N, D_in, H, D_out = 64, 1000, 100, 10
x = torch.randn(N, D_in, device=device)
y = torch.randn(N, D_out, device=device)
w1 = torch.randn(D_in, H, device=device)
w2 = torch.randn(H, D_out, device=device)

learning_rate = 1e-6
for t in range(500):
    h = x.mm(w1)
    h_relu = h.clamp(min=0)
    y_pred = h_relu.mm(w2)
    loss = (y_pred - y).pow(2).sum()

    grad_y_pred = 2.0 * (y_pred - y)
    grad_w2 = h_relu.t().mm(grad_y_pred)
    grad_h_relu = grad_y_pred.mm(w2.t())
    grad_h = grad_h_relu.clone()
    grad_h[h < 0] = 0
    grad_w1 = x.t().mm(grad_h)

    w1 -= learning_rate * grad_w1
    w2 -= learning_rate * grad_w2
```



# PyTorch: Tensors

Backward pass: manually  
compute gradients



```
import torch

device = torch.device('cpu')

N, D_in, H, D_out = 64, 1000, 100, 10
x = torch.randn(N, D_in, device=device)
y = torch.randn(N, D_out, device=device)
w1 = torch.randn(D_in, H, device=device)
w2 = torch.randn(H, D_out, device=device)
```

```
learning_rate = 1e-6
for t in range(500):
    h = x.mm(w1)
    h_relu = h.clamp(min=0)
    y_pred = h_relu.mm(w2)
    loss = (y_pred - y).pow(2).sum()
```

```
grad_y_pred = 2.0 * (y_pred - y)
grad_w2 = h_relu.t().mm(grad_y_pred)
grad_h_relu = grad_y_pred.mm(w2.t())
grad_h = grad_h_relu.clone()
grad_h[h < 0] = 0
grad_w1 = x.t().mm(grad_h)
```

```
w1 -= learning_rate * grad_w1
w2 -= learning_rate * grad_w2
```



# PyTorch: Tensors

Gradient descent  
step on weights

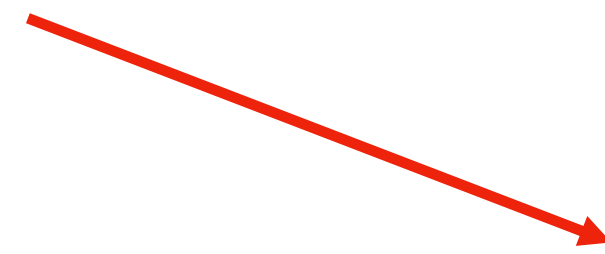

```
import torch

device = torch.device('cpu')

N, D_in, H, D_out = 64, 1000, 100, 10
x = torch.randn(N, D_in, device=device)
y = torch.randn(N, D_out, device=device)
w1 = torch.randn(D_in, H, device=device)
w2 = torch.randn(H, D_out, device=device)

learning_rate = 1e-6
for t in range(500):
    h = x.mm(w1)
    h_relu = h.clamp(min=0)
    y_pred = h_relu.mm(w2)
    loss = (y_pred - y).pow(2).sum()

    grad_y_pred = 2.0 * (y_pred - y)
    grad_w2 = h_relu.t().mm(grad_y_pred)
    grad_h_relu = grad_y_pred.mm(w2.t())
    grad_h = grad_h_relu.clone()
    grad_h[h < 0] = 0
    grad_w1 = x.t().mm(grad_h)
```

```
w1 -= learning_rate * grad_w1
w2 -= learning_rate * grad_w2
```



# PyTorch: Tensors

To run on GPU, just use a different device!



```
import torch

device = torch.device('cpu')

N, D_in, H, D_out = 64, 1000, 100, 10
x = torch.randn(N, D_in, device=device)
y = torch.randn(N, D_out, device=device)
w1 = torch.randn(D_in, H, device=device)
w2 = torch.randn(H, D_out, device=device)

learning_rate = 1e-6
for t in range(500):
    h = x.mm(w1)
    h_relu = h.clamp(min=0)
    y_pred = h_relu.mm(w2)
    loss = (y_pred - y).pow(2).sum()

    grad_y_pred = 2.0 * (y_pred - y)
    grad_w2 = h_relu.t().mm(grad_y_pred)
    grad_h_relu = grad_y_pred.mm(w2.t())
    grad_h = grad_h_relu.clone()
    grad_h[h < 0] = 0
    grad_w1 = x.t().mm(grad_h)

    w1 -= learning_rate * grad_w1
    w2 -= learning_rate * grad_w2
```



# PyTorch: Autograd

Creating Tensors with `requires_grad=True` enables autograd

Operations on Tensors with `requires_grad=True` cause PyTorch to build a computational graph

```
import torch

N, D_in, H, D_out = 64, 1000, 100, 10
x = torch.randn(N, D_in)
y = torch.randn(N, D_out)
w1 = torch.randn(D_in, H, requires_grad=True)
w2 = torch.randn(H, D_out, requires_grad=True)

learning_rate = 1e-6
for t in range(500):
    y_pred = x.mm(w1).clamp(min=0).mm(w2)
    loss = (y_pred - y).pow(2).sum()

    loss.backward()

    with torch.no_grad():
        w1 -= learning_rate * w1.grad
        w2 -= learning_rate * w2.grad
        w1.grad.zero_()
        w2.grad.zero_()
```



# PyTorch: Autograd

We will not want gradients (of loss) with respect to data

Do want gradients with respect to weights

```
import torch

N, D_in, H, D_out = 64, 1000, 100, 10
x = torch.randn(N, D_in)
y = torch.randn(N, D_out)
w1 = torch.randn(D_in, H, requires_grad=True)
w2 = torch.randn(H, D_out, requires_grad=True)

learning_rate = 1e-6
for t in range(500):
    y_pred = x.mm(w1).clamp(min=0).mm(w2)
    loss = (y_pred - y).pow(2).sum()

    loss.backward()

    with torch.no_grad():
        w1 -= learning_rate * w1.grad
        w2 -= learning_rate * w2.grad
        w1.grad.zero_()
        w2.grad.zero_()
```



# PyTorch: Autograd

Compute gradients with respect to all inputs that have `requires_grad=True`!



```
import torch

N, D_in, H, D_out = 64, 1000, 100, 10
x = torch.randn(N, D_in)
y = torch.randn(N, D_out)
w1 = torch.randn(D_in, H, requires_grad=True)
w2 = torch.randn(H, D_out, requires_grad=True)

learning_rate = 1e-6
for t in range(500):
    y_pred = x.mm(w1).clamp(min=0).mm(w2)
    loss = (y_pred - y).pow(2).sum()

    loss.backward()

    with torch.no_grad():
        w1 -= learning_rate * w1.grad
        w2 -= learning_rate * w2.grad
        w1.grad.zero_()
        w2.grad.zero_()
```





# PyTorch: Autograd

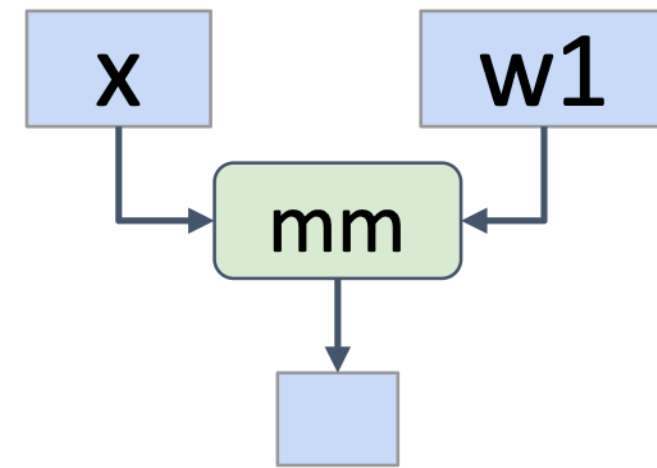

```
import torch

N, D_in, H, D_out = 64, 1000, 100, 10
x = torch.randn(N, D_in)
y = torch.randn(N, D_out)
w1 = torch.randn(D_in, H, requires_grad=True)
w2 = torch.randn(H, D_out, requires_grad=True)

learning_rate = 1e-6
for t in range(500):
    y_pred = x.mm(w1).clamp(min=0).mm(w2)
    loss = (y_pred - y).pow(2).sum()

    loss.backward()

    with torch.no_grad():
        w1 -= learning_rate * w1.grad
        w2 -= learning_rate * w2.grad
        w1.grad.zero_()
        w2.grad.zero_()
```

Every operation on a tensor with `requires_grad=True` will add to the computational graph, and the resulting tensors will also have `requires_grad=True`



# PyTorch: Autograd

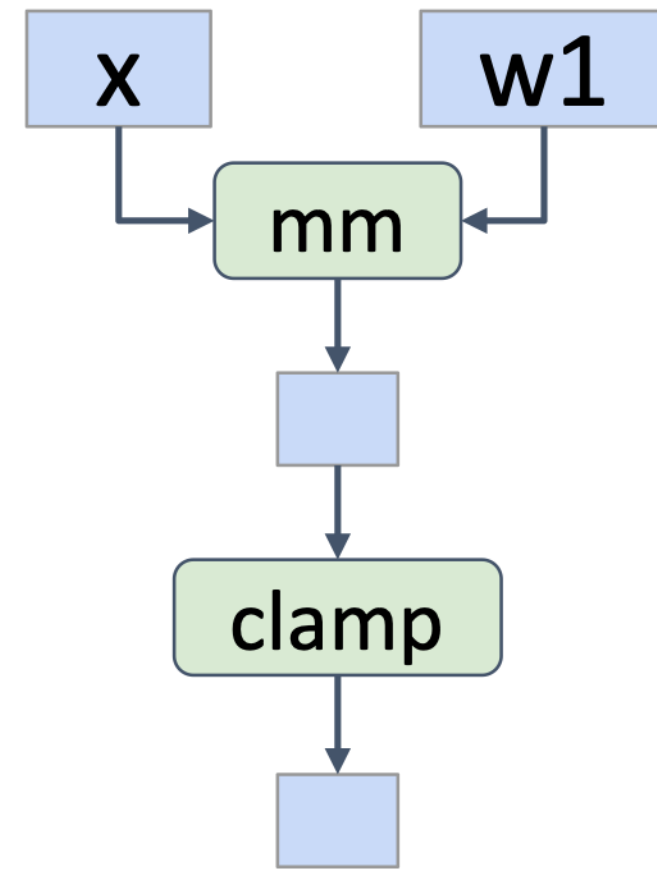

```
import torch

N, D_in, H, D_out = 64, 1000, 100, 10
x = torch.randn(N, D_in)
y = torch.randn(N, D_out)
w1 = torch.randn(D_in, H, requires_grad=True)
w2 = torch.randn(H, D_out, requires_grad=True)

learning_rate = 1e-6
for t in range(500):
    y_pred = x.mm(w1).clamp(min=0).mm(w2)
    loss = (y_pred - y).pow(2).sum()

    loss.backward()

    with torch.no_grad():
        w1 -= learning_rate * w1.grad
        w2 -= learning_rate * w2.grad
        w1.grad.zero_()
        w2.grad.zero_()
```

Every operation on a tensor with `requires_grad=True` will add to the computational graph, and the resulting tensors will also have `requires_grad=True`



# PyTorch: Autograd

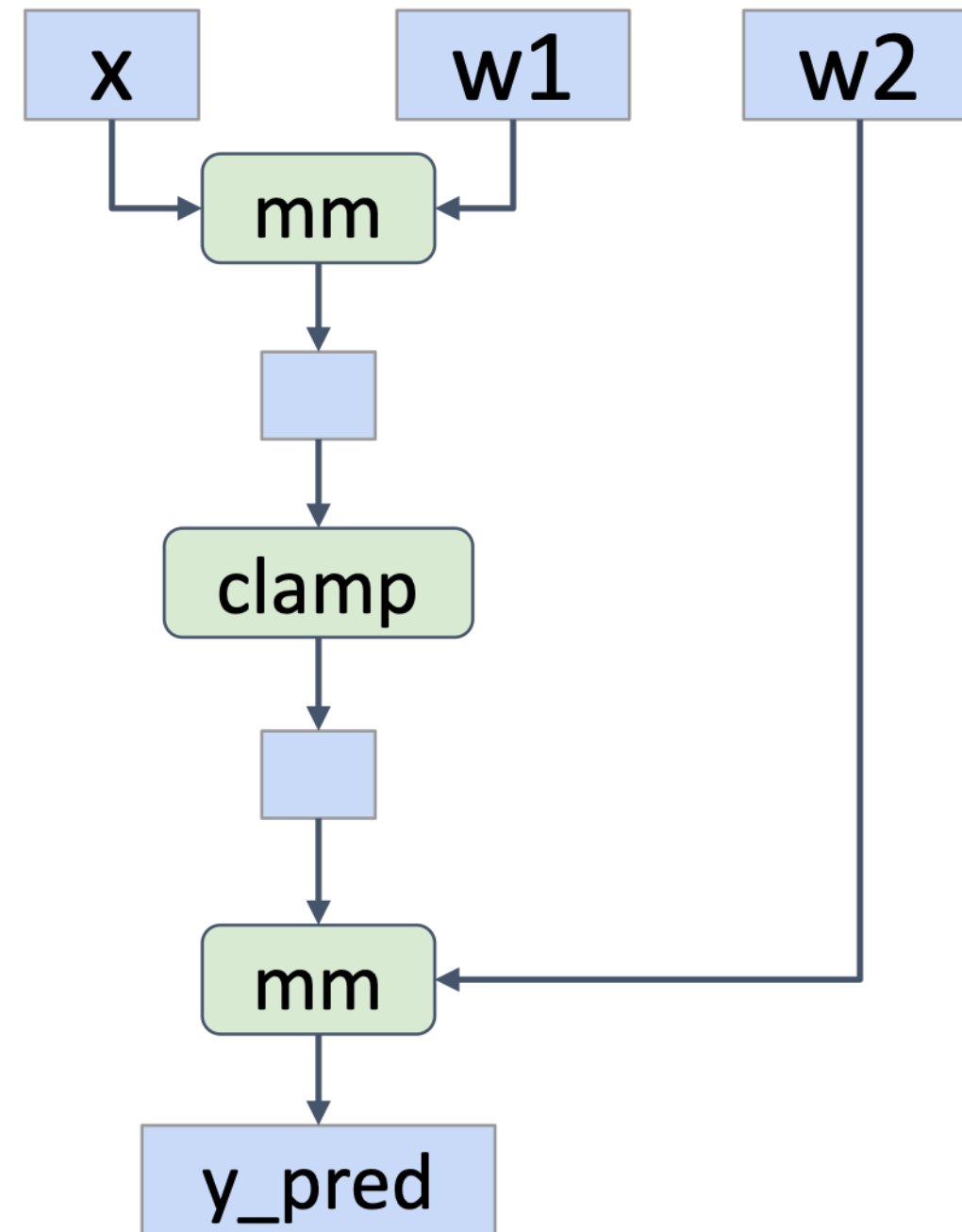

```
import torch

N, D_in, H, D_out = 64, 1000, 100, 10
x = torch.randn(N, D_in)
y = torch.randn(N, D_out)
w1 = torch.randn(D_in, H, requires_grad=True)
w2 = torch.randn(H, D_out, requires_grad=True)

learning_rate = 1e-6
for t in range(500):
    y_pred = x.mm(w1).clamp(min=0).mm(w2)
    loss = (y_pred - y).pow(2).sum()

    loss.backward()

    with torch.no_grad():
        w1 -= learning_rate * w1.grad
        w2 -= learning_rate * w2.grad
        w1.grad.zero_()
        w2.grad.zero_()
```



# PyTorch: Autograd

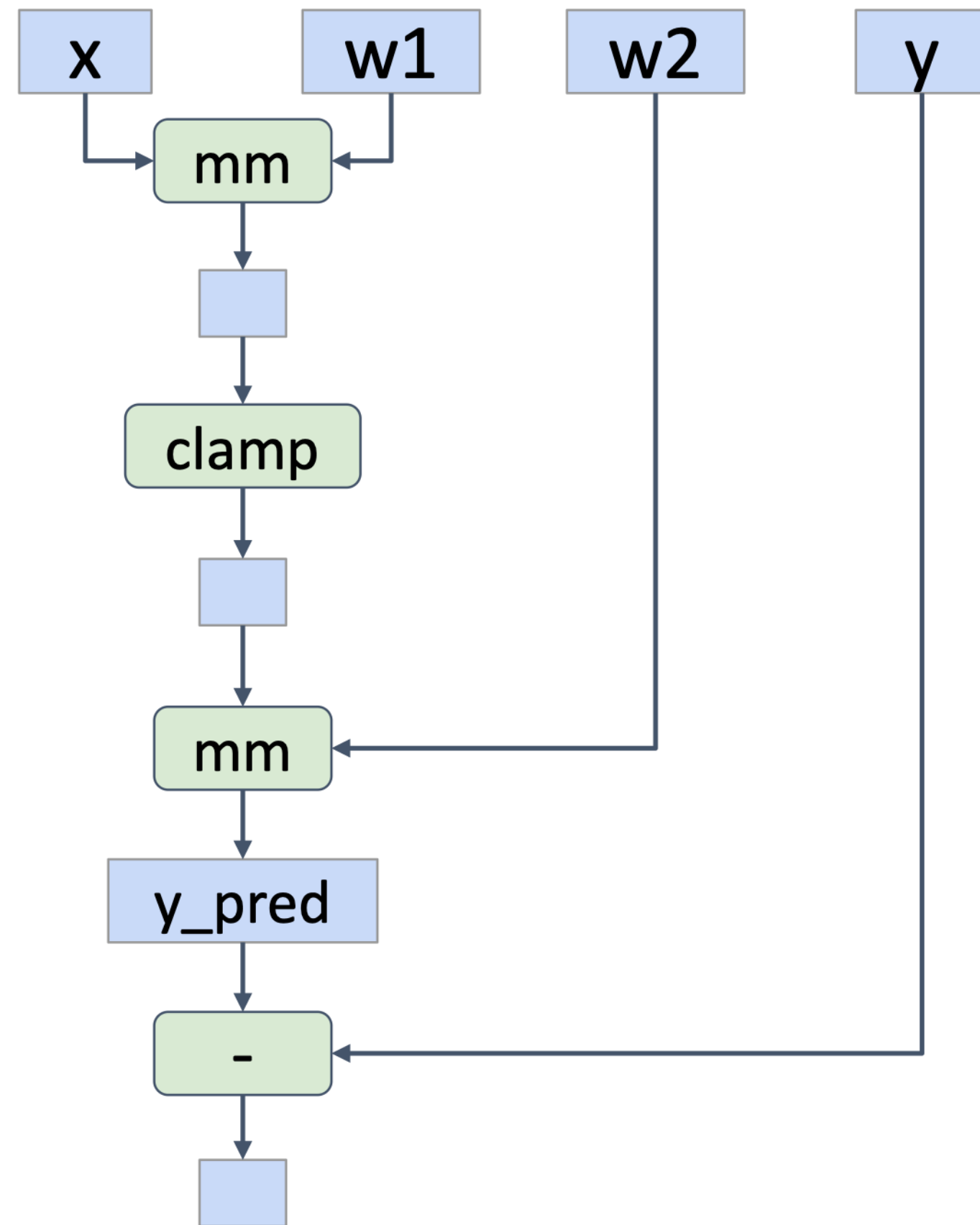

```
import torch

N, D_in, H, D_out = 64, 1000, 100, 10
x = torch.randn(N, D_in)
y = torch.randn(N, D_out)
w1 = torch.randn(D_in, H, requires_grad=True)
w2 = torch.randn(H, D_out, requires_grad=True)

learning_rate = 1e-6
for t in range(500):
    y_pred = x.mm(w1).clamp(min=0).mm(w2)
    loss = (y_pred - y).pow(2).sum()

    loss.backward()

    with torch.no_grad():
        w1 -= learning_rate * w1.grad
        w2 -= learning_rate * w2.grad
        w1.grad.zero_()
        w2.grad.zero_()
```



# PyTorch: Autograd

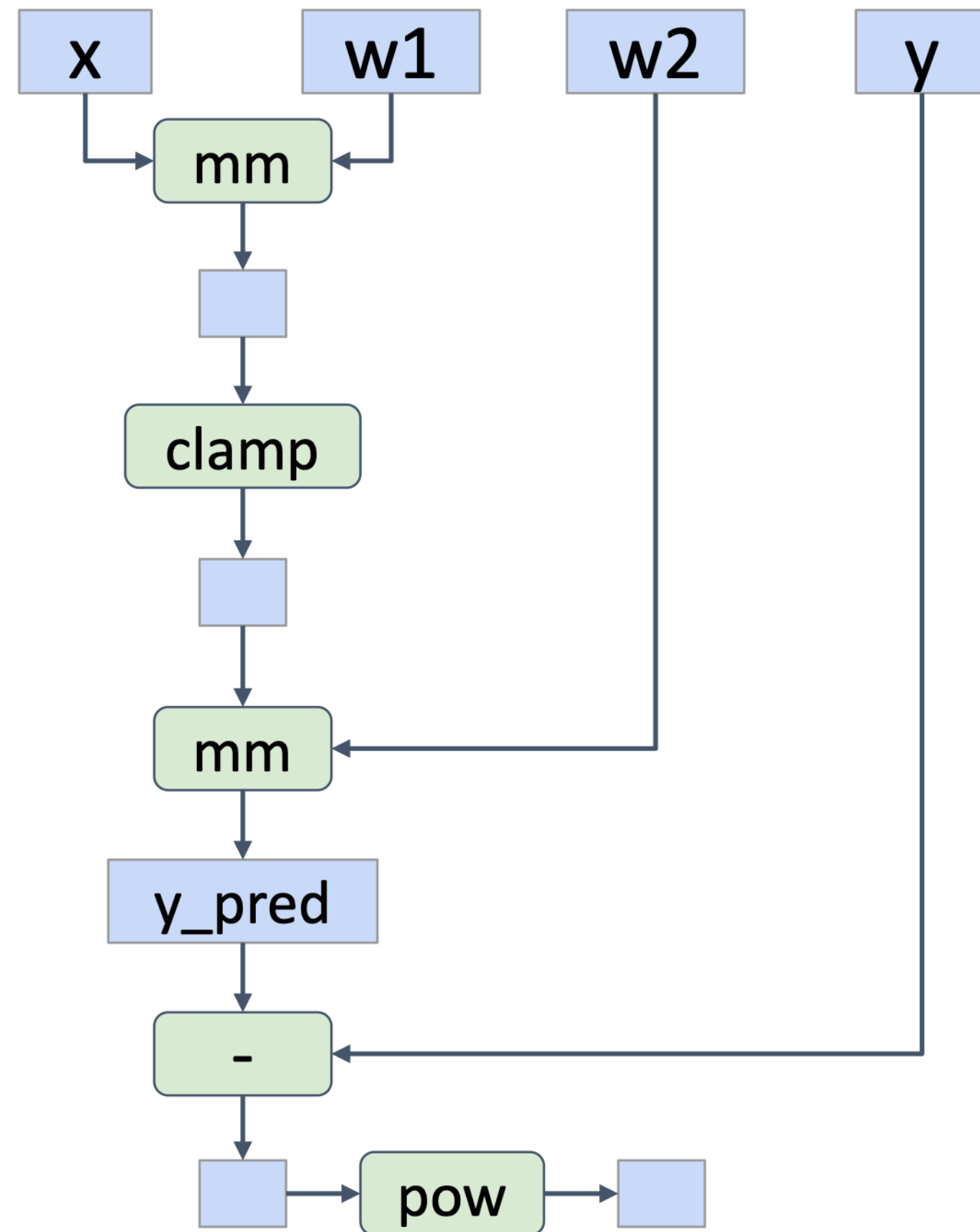

```
import torch

N, D_in, H, D_out = 64, 1000, 100, 10
x = torch.randn(N, D_in)
y = torch.randn(N, D_out)
w1 = torch.randn(D_in, H, requires_grad=True)
w2 = torch.randn(H, D_out, requires_grad=True)

learning_rate = 1e-6
for t in range(500):
    y_pred = x.mm(w1).clamp(min=0).mm(w2)
    loss = (y_pred - y).pow(2).sum()

    loss.backward()

    with torch.no_grad():
        w1 -= learning_rate * w1.grad
        w2 -= learning_rate * w2.grad
        w1.grad.zero_()
        w2.grad.zero_()
```



# PyTorch: Autograd

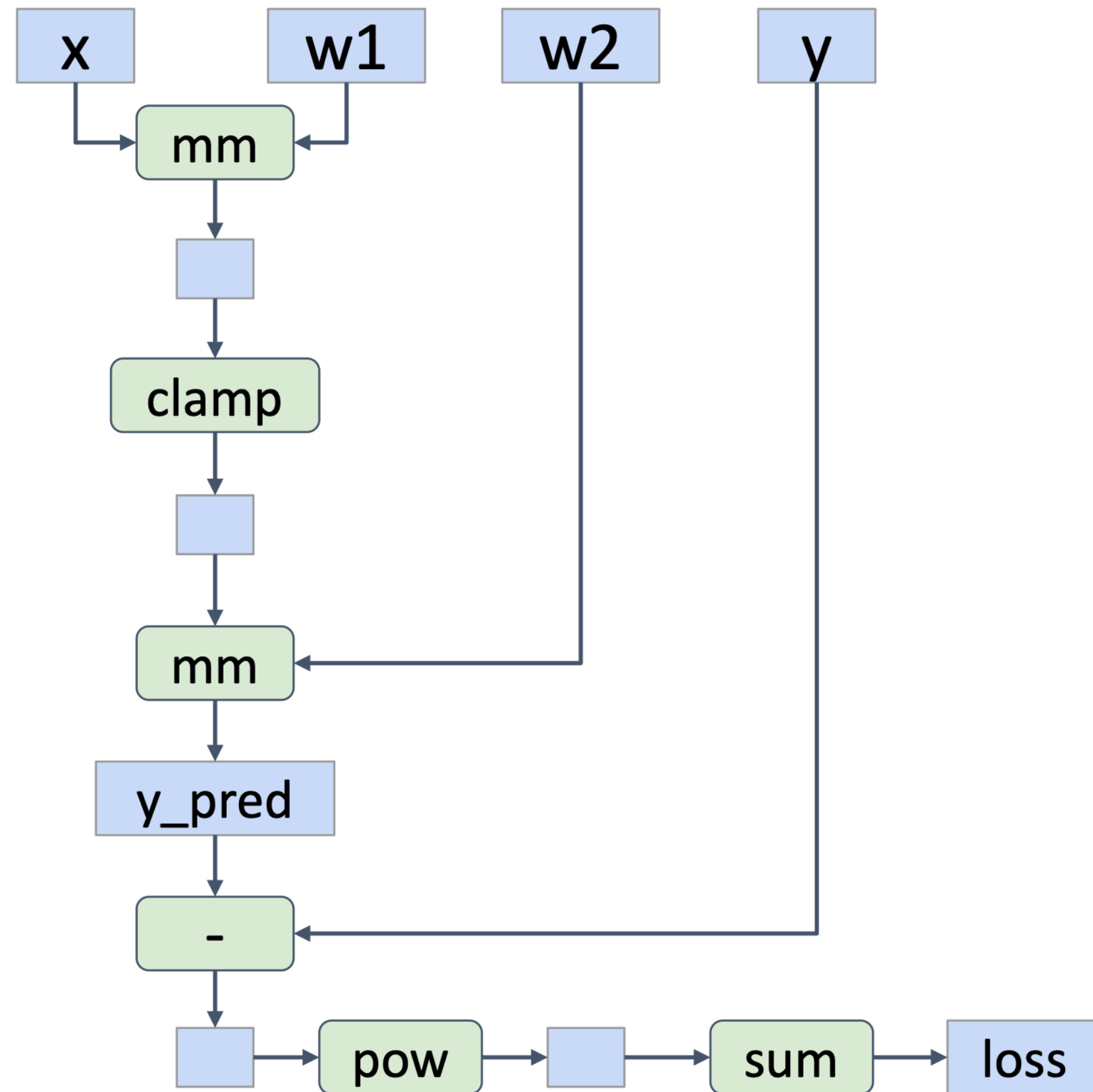

```
import torch

N, D_in, H, D_out = 64, 1000, 100, 10
x = torch.randn(N, D_in)
y = torch.randn(N, D_out)
w1 = torch.randn(D_in, H, requires_grad=True)
w2 = torch.randn(H, D_out, requires_grad=True)

learning_rate = 1e-6
for t in range(500):
    y_pred = x.mm(w1).clamp(min=0).mm(w2)
    loss = (y_pred - y).pow(2).sum()

    loss.backward()

    with torch.no_grad():
        w1 -= learning_rate * w1.grad
        w2 -= learning_rate * w2.grad
        w1.grad.zero_()
        w2.grad.zero_()
```



# PyTorch: Autograd

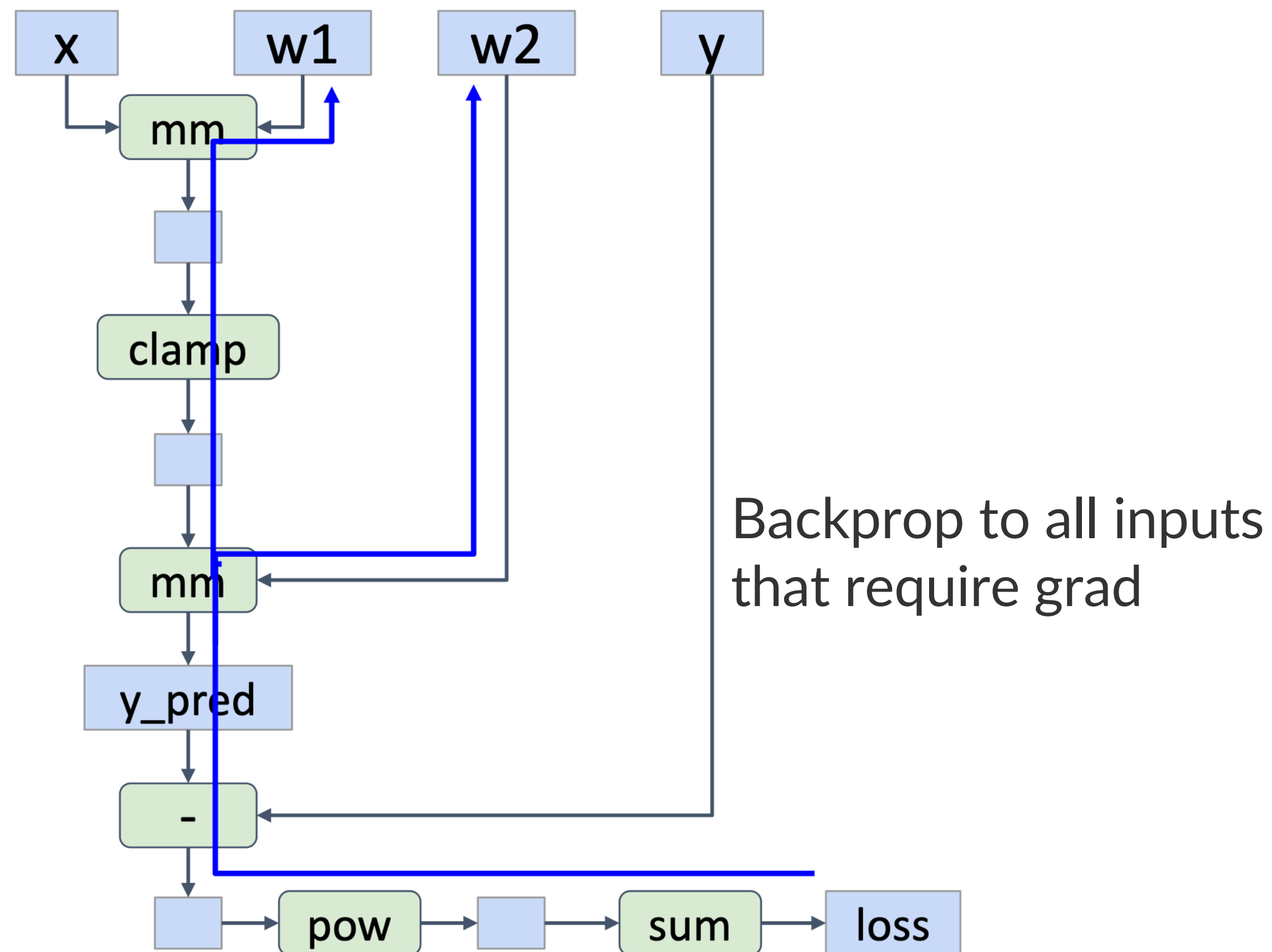

```
import torch

N, D_in, H, D_out = 64, 1000, 100, 10
x = torch.randn(N, D_in)
y = torch.randn(N, D_out)
w1 = torch.randn(D_in, H, requires_grad=True)
w2 = torch.randn(H, D_out, requires_grad=True)

learning_rate = 1e-6
for t in range(500):
    y_pred = x.mm(w1).clamp(min=0).mm(w2)
    loss = (y_pred - y).pow(2).sum()

    loss.backward()

    with torch.no_grad():
        w1 -= learning_rate * w1.grad
        w2 -= learning_rate * w2.grad
        w1.grad.zero_()
        w2.grad.zero_()
```



# PyTorch: Autograd



After backward finishes, gradients are accumulated into `w1.grad` and `w2.grad` and the graph is destroyed



```
import torch

N, D_in, H, D_out = 64, 1000, 100, 10
x = torch.randn(N, D_in)
y = torch.randn(N, D_out)
w1 = torch.randn(D_in, H, requires_grad=True)
w2 = torch.randn(H, D_out, requires_grad=True)

learning_rate = 1e-6
for t in range(500):
    y_pred = x.mm(w1).clamp(min=0).mm(w2)
    loss = (y_pred - y).pow(2).sum()

    loss.backward()

    with torch.no_grad():
        w1 -= learning_rate * w1.grad
        w2 -= learning_rate * w2.grad
        w1.grad.zero_()
        w2.grad.zero_()
```





# PyTorch: Autograd



After backward finishes, gradients are accumulated into `w1.grad` and `w2.grad` and the graph is destroyed

Make gradient step on weights

```
import torch

N, D_in, H, D_out = 64, 1000, 100, 10
x = torch.randn(N, D_in)
y = torch.randn(N, D_out)
w1 = torch.randn(D_in, H, requires_grad=True)
w2 = torch.randn(H, D_out, requires_grad=True)

learning_rate = 1e-6
for t in range(500):
    y_pred = x.mm(w1).clamp(min=0).mm(w2)
    loss = (y_pred - y).pow(2).sum()

    loss.backward()

    with torch.no_grad():
        w1 -= learning_rate * w1.grad
        w2 -= learning_rate * w2.grad
        w1.grad.zero_()
        w2.grad.zero_()
```





# PyTorch: Autograd



After backward finishes, gradients are accumulated into w1.grad and w2.grad and the graph is destroyed

Set gradients to zero—forgetting this is a common bug!

```
import torch

N, D_in, H, D_out = 64, 1000, 100, 10
x = torch.randn(N, D_in)
y = torch.randn(N, D_out)
w1 = torch.randn(D_in, H, requires_grad=True)
w2 = torch.randn(H, D_out, requires_grad=True)

learning_rate = 1e-6
for t in range(500):
    y_pred = x.mm(w1).clamp(min=0).mm(w2)
    loss = (y_pred - y).pow(2).sum()

    loss.backward()

    with torch.no_grad():
        w1 -= learning_rate * w1.grad
        w2 -= learning_rate * w2.grad
        w1.grad.zero_()
        w2.grad.zero_()
```





# PyTorch: Autograd



After backward finishes, gradients are accumulated into `w1.grad` and `w2.grad` and the graph is destroyed

Tell PyTorch not to build a graph for these operations

```
import torch

N, D_in, H, D_out = 64, 1000, 100, 10
x = torch.randn(N, D_in)
y = torch.randn(N, D_out)
w1 = torch.randn(D_in, H, requires_grad=True)
w2 = torch.randn(H, D_out, requires_grad=True)

learning_rate = 1e-6
for t in range(500):
    y_pred = x.mm(w1).clamp(min=0).mm(w2)
    loss = (y_pred - y).pow(2).sum()

    loss.backward()

    with torch.no_grad():
        w1 -= learning_rate * w1.grad
        w2 -= learning_rate * w2.grad
        w1.grad.zero_()
        w2.grad.zero_()
```





# PyTorch: New Functions

Can define new operations  
using Python functions

```
def sigmoid(x):  
    return 1.0 / (1.0 + (-x).exp())
```

```
import torch  
  
N, D_in, H, D_out = 64, 1000, 100, 10  
  
x = torch.randn(N, D_in)  
y = torch.randn(N, D_out)  
y = torch.randn(N, D_out)  
w1 = torch.randn(D_in, H, requires_grad=True)  
w2 = torch.randn(H, D_out, requires_grad=True)  
  
learning_rate = 1e-6  
for t in range(500):  
    y_pred = sigmoid(x.mm(w1)).mm(w2)  
    loss = (y_pred - y).pow(2).sum()  
  
    loss.backward()  
    if t % 50 == 0:  
        print(t, loss.item())  
  
    with torch.no_grad():  
        w1 -= learning_rate * w1.grad  
        w2 -= learning_rate * w2.grad  
        w1.grad.zero_()  
        w2.grad.zero_()
```



# PyTorch: New Functions

Can define new operations using Python functions

```
def sigmoid(x):  
    return 1.0 / (1.0 + (-x).exp())
```

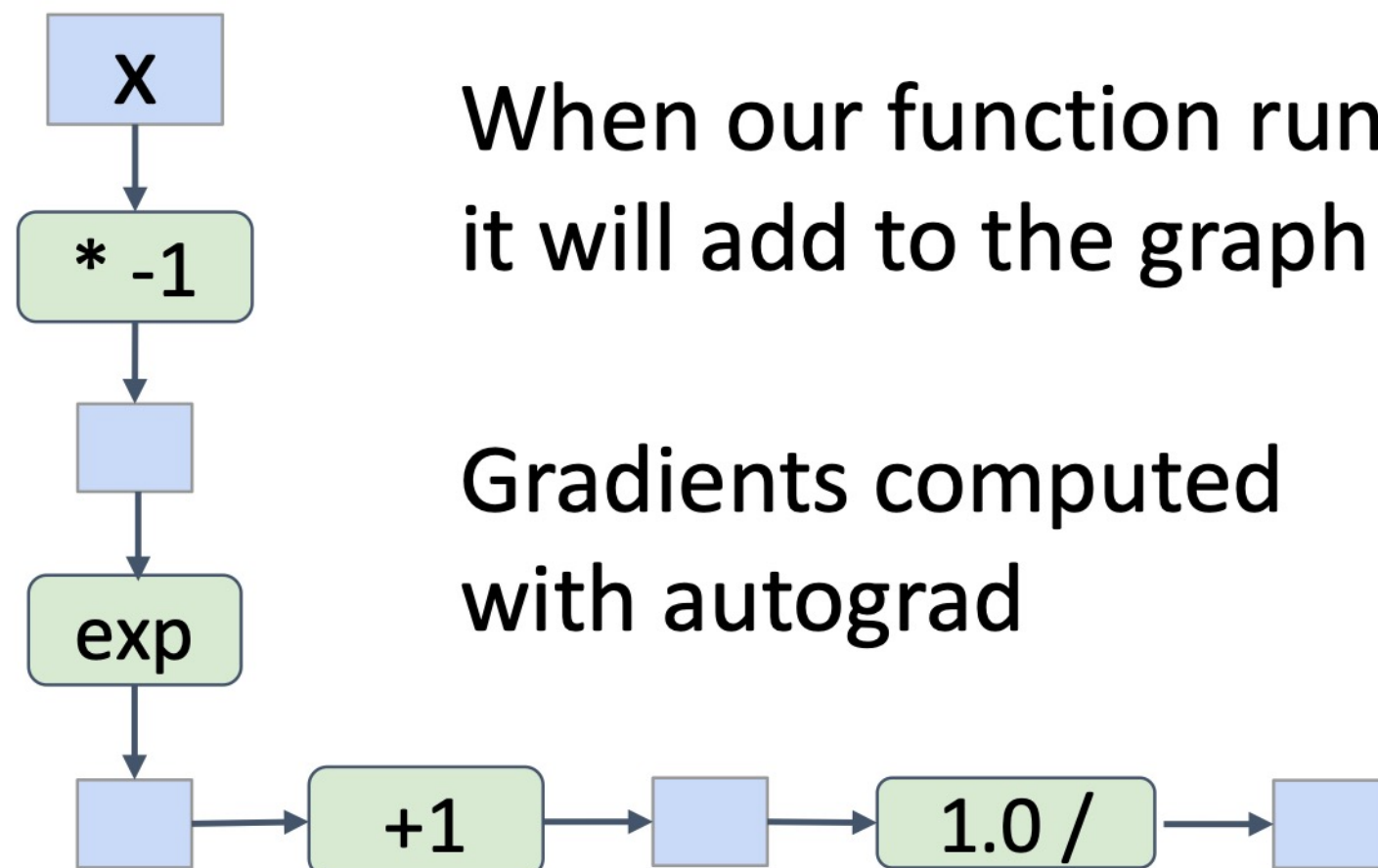

When our function runs, it will add to the graph

Gradients computed with autograd

```
import torch  
  
N, D_in, H, D_out = 64, 1000, 100, 10  
  
x = torch.randn(N, D_in)  
y = torch.randn(N, D_out)  
y = torch.randn(N, D_out)  
w1 = torch.randn(D_in, H, requires_grad=True)  
w2 = torch.randn(H, D_out, requires_grad=True)  
  
learning_rate = 1e-6  
for t in range(500):  
    y_pred = sigmoid(x.mm(w1)).mm(w2)  
    loss = (y_pred - y).pow(2).sum()  
  
    loss.backward()  
    if t % 50 == 0:  
        print(t, loss.item())  
  
    with torch.no_grad():  
        w1 -= learning_rate * w1.grad  
        w2 -= learning_rate * w2.grad  
        w1.grad.zero_()  
        w2.grad.zero_()
```



# PyTorch: New Functions

Can define new operations using Python functions

```
def sigmoid(x):
    return 1.0 / (1.0 + (-x).exp())
```

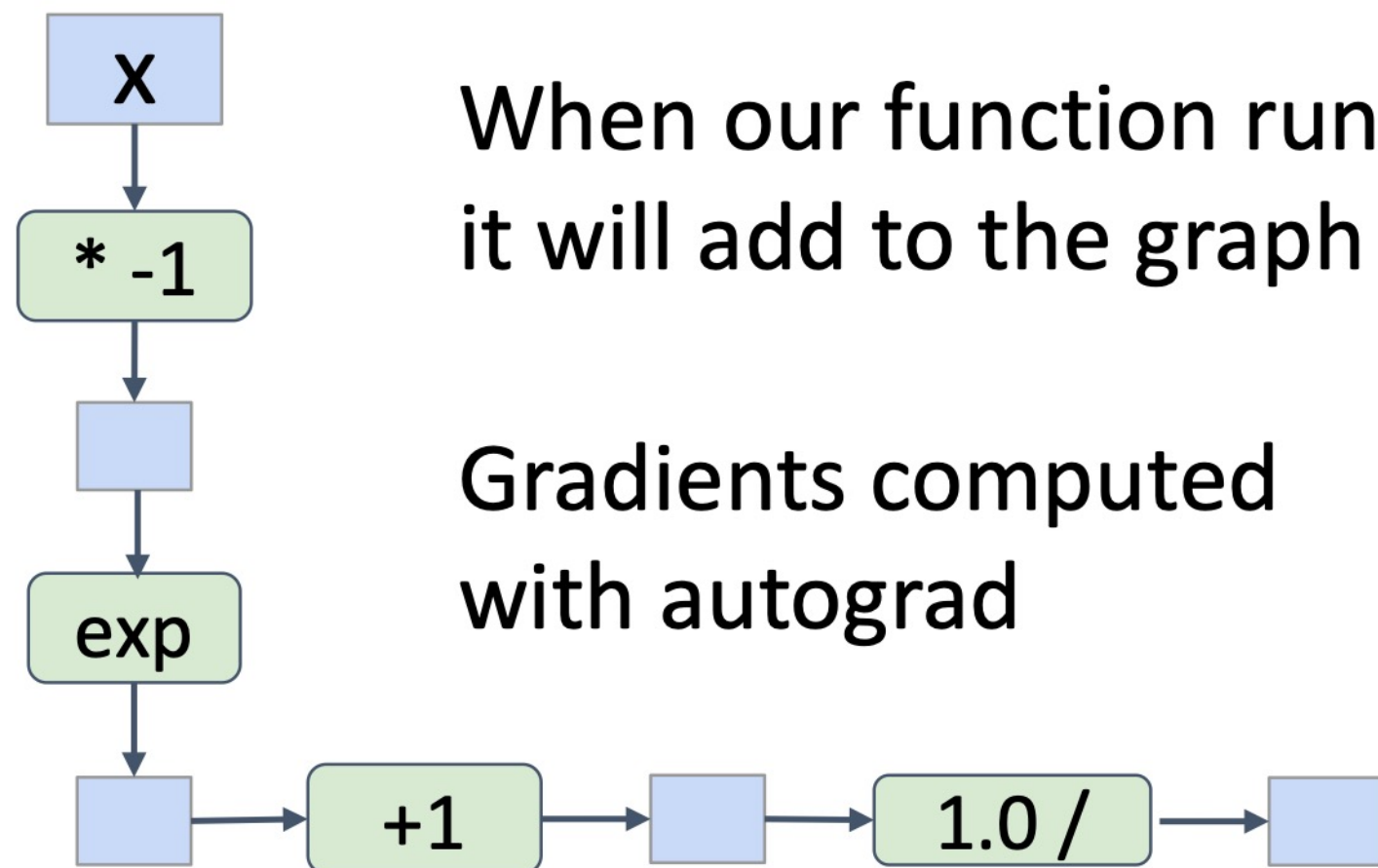

When our function runs, it will add to the graph

Gradients computed with autograd

Define new autograd operators by subclassing Function, define forward and backward

```

class Sigmoid(torch.autograd.Function):
    @staticmethod
    def forward(ctx, x):
        y = 1.0 / (1.0 + (-x).exp())
        ctx.save_for_backward(y)
        return y

    @staticmethod
    def backward(ctx, grad_y):
        y, = ctx.saved_tensors
        grad_x = grad_y * y * (1.0 - y)
        return grad_x

def sigmoid(x):
    return Sigmoid.apply(x)
  
```

Recall:  $\frac{\partial}{\partial x} [\sigma(x)] = (1 - \sigma(x))\sigma(x)$



# PyTorch: New Functions

Can define new operations using Python functions

```
def sigmoid(x):
    return 1.0 / (1.0 + (-x).exp())
```

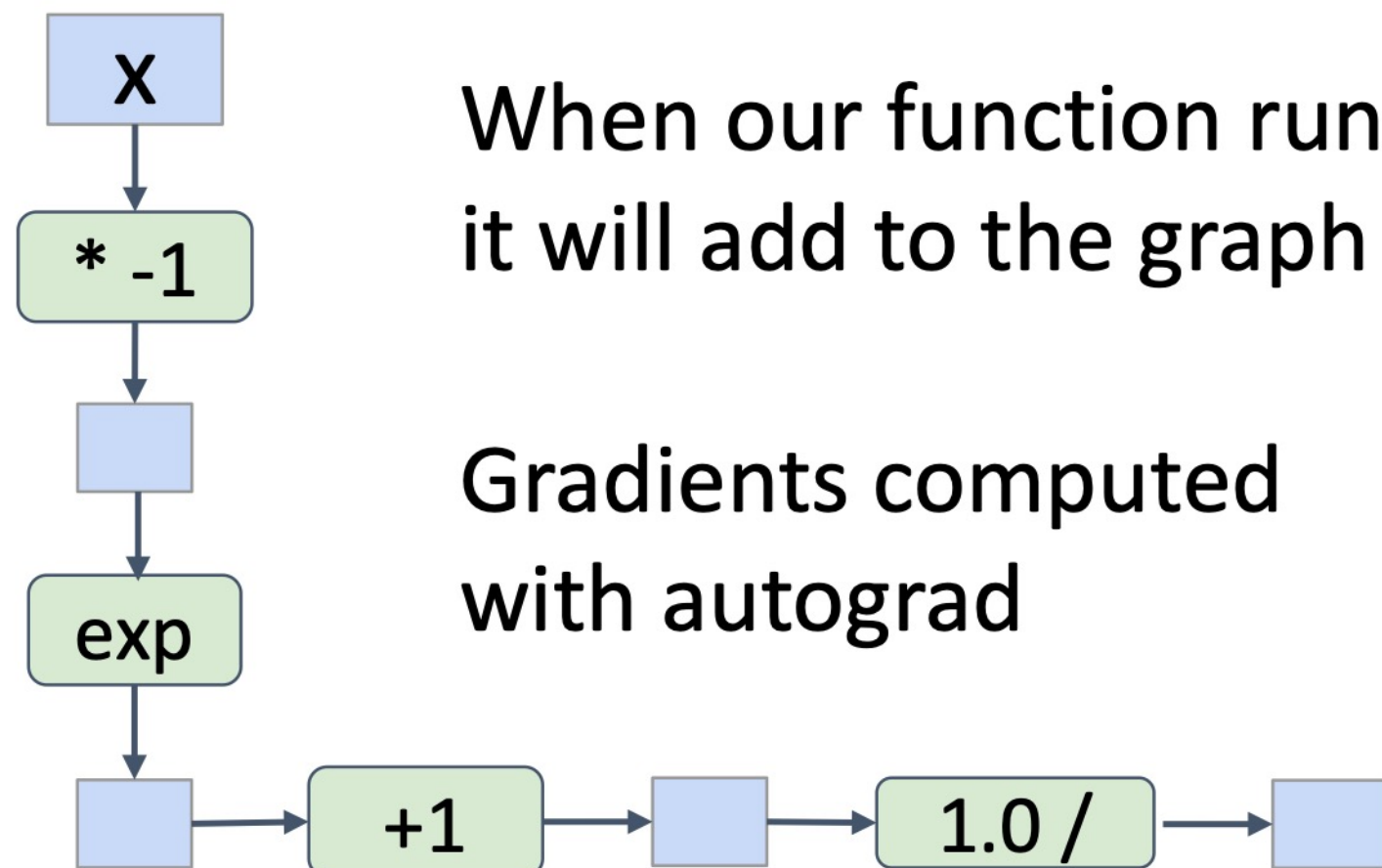

When our function runs, it will add to the graph

Gradients computed with autograd

Define new autograd operators by subclassing Function, define forward and backward

```
class Sigmoid(torch.autograd.Function):
    @staticmethod
    def forward(ctx, x):
        y = 1.0 / (1.0 + (-x).exp())
        ctx.save_for_backward(y)
        return y

    @staticmethod
    def backward(ctx, grad_y):
        y, = ctx.saved_tensors
        grad_x = grad_y * y * (1.0 - y)
        return grad_x

def sigmoid(x):
    return Sigmoid.apply(x)
```

Now when our function runs, it adds one node to the graph!

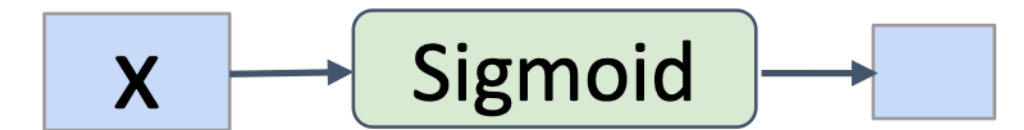



# PyTorch: New Functions

Can define new operations using Python functions

```
def sigmoid(x):
    return 1.0 / (1.0 + (-x).exp())
```

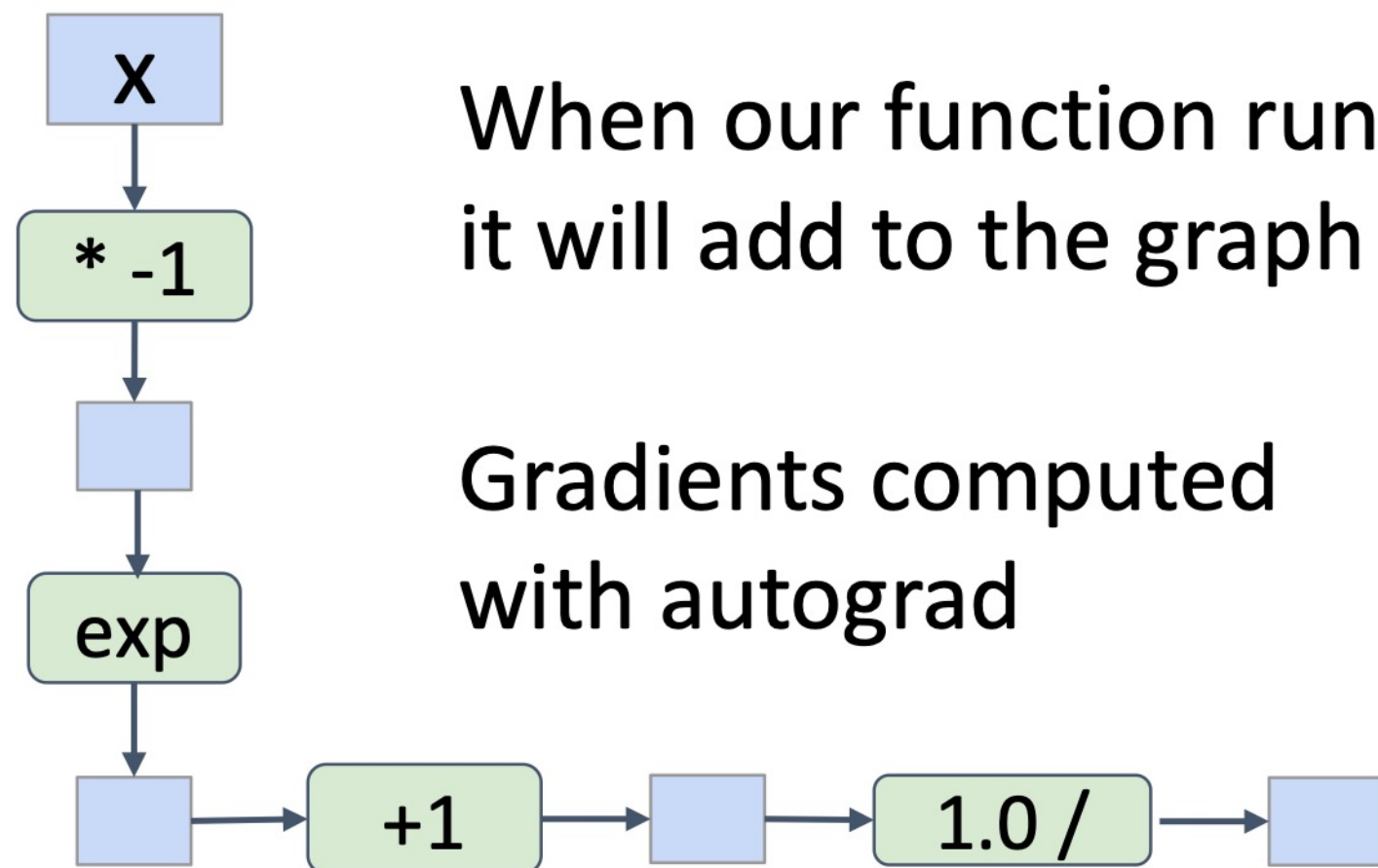

When our function runs, it will add to the graph

Gradients computed with autograd

Define new autograd operators by subclassing Function, define forward and backward

```

class Sigmoid(torch.autograd.Function):
    @staticmethod
    def forward(ctx, x):
        y = 1.0 / (1.0 + (-x).exp())
        ctx.save_for_backward(y)
        return y

    @staticmethod
    def backward(ctx, grad_y):
        y, = ctx.saved_tensors
        grad_x = grad_y * y * (1.0 - y)
        return grad_x

def sigmoid(x):
    return Sigmoid.apply(x)
  
```

In practice this is pretty rare – in most cases Python functions are good enough





# PyTorch: nn

Higher-level wrapper for  
working with neural nets

Use this! It will make your  
life easier

```
import torch

N, D_in, H, D_out = 64, 1000, 100, 10
x = torch.randn(N, D_in)
y = torch.randn(N, D_out)

model = torch.nn.Sequential(
    torch.nn.Linear(D_in, H),
    torch.nn.ReLU(),
    torch.nn.Linear(H, D_out))

learning_rate = 1e-2
for t in range(500):
    y_pred = model(x)
    loss = torch.nn.functional.mse_loss(y_pred, y)

    loss.backward()

    with torch.no_grad():
        for param in model.parameters():
            param -= learning_rate * param.grad
    model.zero_grad()
```



# PyTorch: nn

Object-oriented API: Define model object as sequence of layers objects, each of which holds weight tensors

```
import torch

N, D_in, H, D_out = 64, 1000, 100, 10
x = torch.randn(N, D_in)
y = torch.randn(N, D_out)

model = torch.nn.Sequential(
    torch.nn.Linear(D_in, H),
    torch.nn.ReLU(),
    torch.nn.Linear(H, D_out))

learning_rate = 1e-2
for t in range(500):
    y_pred = model(x)
    loss = torch.nn.functional.mse_loss(y_pred, y)

    loss.backward()

    with torch.no_grad():
        for param in model.parameters():
            param -= learning_rate * param.grad
    model.zero_grad()
```



# PyTorch: nn

Forward pass: Feed data to model and compute loss

```
import torch

N, D_in, H, D_out = 64, 1000, 100, 10
x = torch.randn(N, D_in)
y = torch.randn(N, D_out)

model = torch.nn.Sequential(
    torch.nn.Linear(D_in, H),
    torch.nn.ReLU(),
    torch.nn.Linear(H, D_out))

learning_rate = 1e-2
for t in range(500):
    y_pred = model(x)
    loss = torch.nn.functional.mse_loss(y_pred, y)

    loss.backward()

    with torch.no_grad():
        for param in model.parameters():
            param -= learning_rate * param.grad
    model.zero_grad()
```



# PyTorch: nn

Forward pass: Feed data to model and compute loss

torch.nn.functional has useful helpers like loss functions

```
import torch

N, D_in, H, D_out = 64, 1000, 100, 10
x = torch.randn(N, D_in)
y = torch.randn(N, D_out)

model = torch.nn.Sequential(
    torch.nn.Linear(D_in, H),
    torch.nn.ReLU(),
    torch.nn.Linear(H, D_out))

learning_rate = 1e-2
for t in range(500):
    y_pred = model(x)
    loss = torch.nn.functional.mse_loss(y_pred, y)
    loss.backward()

    with torch.no_grad():
        for param in model.parameters():
            param -= learning_rate * param.grad
    model.zero_grad()
```

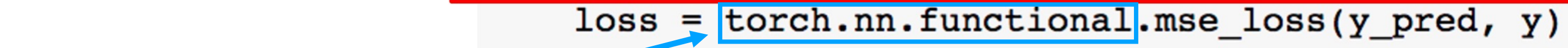
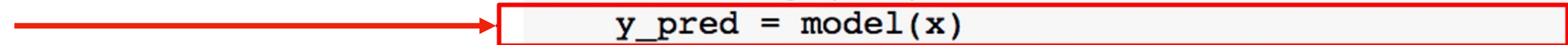



# PyTorch: nn

Backward pass: compute gradient with respect to all model weights (they have `requires_grad=True`)

```
import torch

N, D_in, H, D_out = 64, 1000, 100, 10
x = torch.randn(N, D_in)
y = torch.randn(N, D_out)

model = torch.nn.Sequential(
    torch.nn.Linear(D_in, H),
    torch.nn.ReLU(),
    torch.nn.Linear(H, D_out))

learning_rate = 1e-2
for t in range(500):
    y_pred = model(x)
    loss = torch.nn.functional.mse_loss(y_pred, y)
    loss.backward()

    with torch.no_grad():
        for param in model.parameters():
            param -= learning_rate * param.grad
    model.zero_grad()
```



# PyTorch: nn

Make gradient step on each model parameter (with gradients disabled)

```
import torch

N, D_in, H, D_out = 64, 1000, 100, 10
x = torch.randn(N, D_in)
y = torch.randn(N, D_out)

model = torch.nn.Sequential(
    torch.nn.Linear(D_in, H),
    torch.nn.ReLU(),
    torch.nn.Linear(H, D_out))

learning_rate = 1e-2
for t in range(500):
    y_pred = model(x)
    loss = torch.nn.functional.mse_loss(y_pred, y)

    loss.backward()

    with torch.no_grad():
        for param in model.parameters():
            param -= learning_rate * param.grad
    model.zero_grad()
```





# PyTorch: optim

Use an **optimizer** for different update rules



```
import torch

N, D_in, H, D_out = 64, 1000, 100, 10
x = torch.randn(N, D_in)
y = torch.randn(N, D_out)

model = torch.nn.Sequential(
    torch.nn.Linear(D_in, H),
    torch.nn.ReLU(),
    torch.nn.Linear(H, D_out))

learning_rate = 1e-4
optimizer = torch.optim.Adam(model.parameters(),
                              lr=learning_rate)
for t in range(500):
    y_pred = model(x)
    loss = torch.nn.functional.mse_loss(y_pred, y)

    loss.backward()

    optimizer.step()
    optimizer.zero_grad()
```



# PyTorch: optim

After computing gradients, use optimizer to update and zero gradients

```
import torch

N, D_in, H, D_out = 64, 1000, 100, 10
x = torch.randn(N, D_in)
y = torch.randn(N, D_out)

model = torch.nn.Sequential(
    torch.nn.Linear(D_in, H),
    torch.nn.ReLU(),
    torch.nn.Linear(H, D_out))

learning_rate = 1e-4
optimizer = torch.optim.Adam(model.parameters(),
                              lr=learning_rate)

for t in range(500):
    y_pred = model(x)
    loss = torch.nn.functional.mse_loss(y_pred, y)

    loss.backward()

    optimizer.step()
    optimizer.zero_grad()
```





# PyTorch: nn

## Defining Modules

A PyTorch **Module** is a neural net layer; it inputs and outputs Tensors

Modules can contain weights or other modules

Very common to define your own models or layers as custom Modules

```
import torch

class TwoLayerNet(torch.nn.Module):
    def __init__(self, D_in, H, D_out):
        super(TwoLayerNet, self).__init__()
        self.linear1 = torch.nn.Linear(D_in, H)
        self.linear2 = torch.nn.Linear(H, D_out)

    def forward(self, x):
        h_relu = self.linear1(x).clamp(min=0)
        y_pred = self.linear2(h_relu)
        return y_pred

N, D_in, H, D_out = 64, 1000, 100, 10
x = torch.randn(N, D_in)
y = torch.randn(N, D_out)

model = TwoLayerNet(D_in, H, D_out)

optimizer = torch.optim.SGD(model.parameters(), lr=1e-4)
for t in range(500):
    y_pred = model(x)
    loss = torch.nn.functional.mse_loss(y_pred, y)

    loss.backward()
    optimizer.step()
    optimizer.zero_grad()
```



# PyTorch: nn

## Defining Modules

Define our whole model as  
a single Module

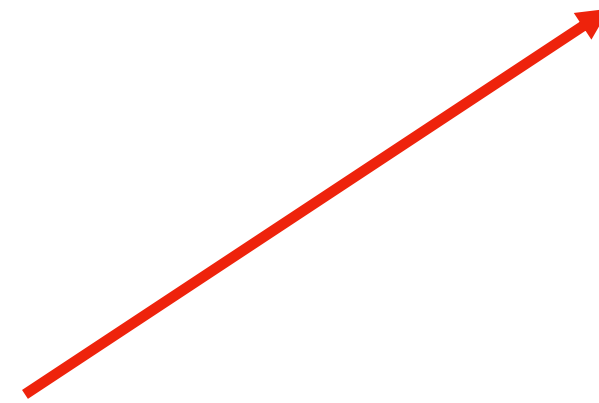

```
import torch

class TwoLayerNet(torch.nn.Module):
    def __init__(self, D_in, H, D_out):
        super(TwoLayerNet, self).__init__()
        self.linear1 = torch.nn.Linear(D_in, H)
        self.linear2 = torch.nn.Linear(H, D_out)

    def forward(self, x):
        h_relu = self.linear1(x).clamp(min=0)
        y_pred = self.linear2(h_relu)
        return y_pred

N, D_in, H, D_out = 64, 1000, 100, 10
x = torch.randn(N, D_in)
y = torch.randn(N, D_out)

model = TwoLayerNet(D_in, H, D_out)

optimizer = torch.optim.SGD(model.parameters(), lr=1e-4)
for t in range(500):
    y_pred = model(x)
    loss = torch.nn.functional.mse_loss(y_pred, y)

    loss.backward()
    optimizer.step()
    optimizer.zero_grad()
```



# PyTorch: nn

## Defining Modules

Initializer sets up two children (Modules can contain modules)

```
import torch

class TwoLayerNet(torch.nn.Module):
    def __init__(self, D_in, H, D_out):
        super(TwoLayerNet, self).__init__()
        self.linear1 = torch.nn.Linear(D_in, H)
        self.linear2 = torch.nn.Linear(H, D_out)

    def forward(self, x):
        h_relu = self.linear1(x).clamp(min=0)
        y_pred = self.linear2(h_relu)
        return y_pred

N, D_in, H, D_out = 64, 1000, 100, 10
x = torch.randn(N, D_in)
y = torch.randn(N, D_out)

model = TwoLayerNet(D_in, H, D_out)

optimizer = torch.optim.SGD(model.parameters(), lr=1e-4)
for t in range(500):
    y_pred = model(x)
    loss = torch.nn.functional.mse_loss(y_pred, y)

    loss.backward()
    optimizer.step()
    optimizer.zero_grad()
```





# PyTorch: nn Defining Modules

Define forward pass using child modules and tensor operations

No need to define backward - autograd will handle it

```
import torch

class TwoLayerNet(torch.nn.Module):
    def __init__(self, D_in, H, D_out):
        super(TwoLayerNet, self).__init__()
        self.linear1 = torch.nn.Linear(D_in, H)
        self.linear2 = torch.nn.Linear(H, D_out)
```

```
    def forward(self, x):
        h_relu = self.linear1(x).clamp(min=0)
        y_pred = self.linear2(h_relu)
        return y_pred
```

```
N, D_in, H, D_out = 64, 1000, 100, 10
x = torch.randn(N, D_in)
y = torch.randn(N, D_out)
```

```
model = TwoLayerNet(D_in, H, D_out)
```

```
optimizer = torch.optim.SGD(model.parameters(), lr=1e-4)
for t in range(500):
    y_pred = model(x)
    loss = torch.nn.functional.mse_loss(y_pred, y)
```

```
    loss.backward()
    optimizer.step()
    optimizer.zero_grad()
```



# PyTorch: nn Defining Modules

Very common to mix and match  
custom Module subclasses and  
Sequential containers



```
import torch

class ParallelBlock(torch.nn.Module):
    def __init__(self, D_in, D_out):
        super(ParallelBlock, self).__init__()
        self.linear1 = torch.nn.Linear(D_in, D_out)
        self.linear2 = torch.nn.Linear(D_in, D_out)
    def forward(self, x):
        h1 = self.linear1(x)
        h2 = self.linear2(x)
        return (h1 * h2).clamp(min=0)

N, D_in, H, D_out = 64, 1000, 100, 10
x = torch.randn(N, D_in)
y = torch.randn(N, D_out)

model = torch.nn.Sequential(
    ParallelBlock(D_in, H),
    ParallelBlock(H, H),
    torch.nn.Linear(H, D_out))

optimizer = torch.optim.Adam(model.parameters(), lr=1e-4)
for t in range(500):
    y_pred = model(x)
    loss = torch.nn.functional.mse_loss(y_pred, y)
    loss.backward()
    optimizer.step()
    optimizer.zero_grad()
```



# PyTorch: nn Defining Modules

Define network component  
as a Module subclass

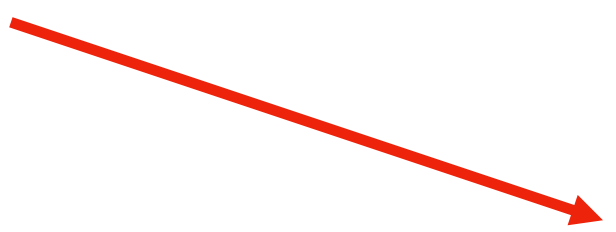
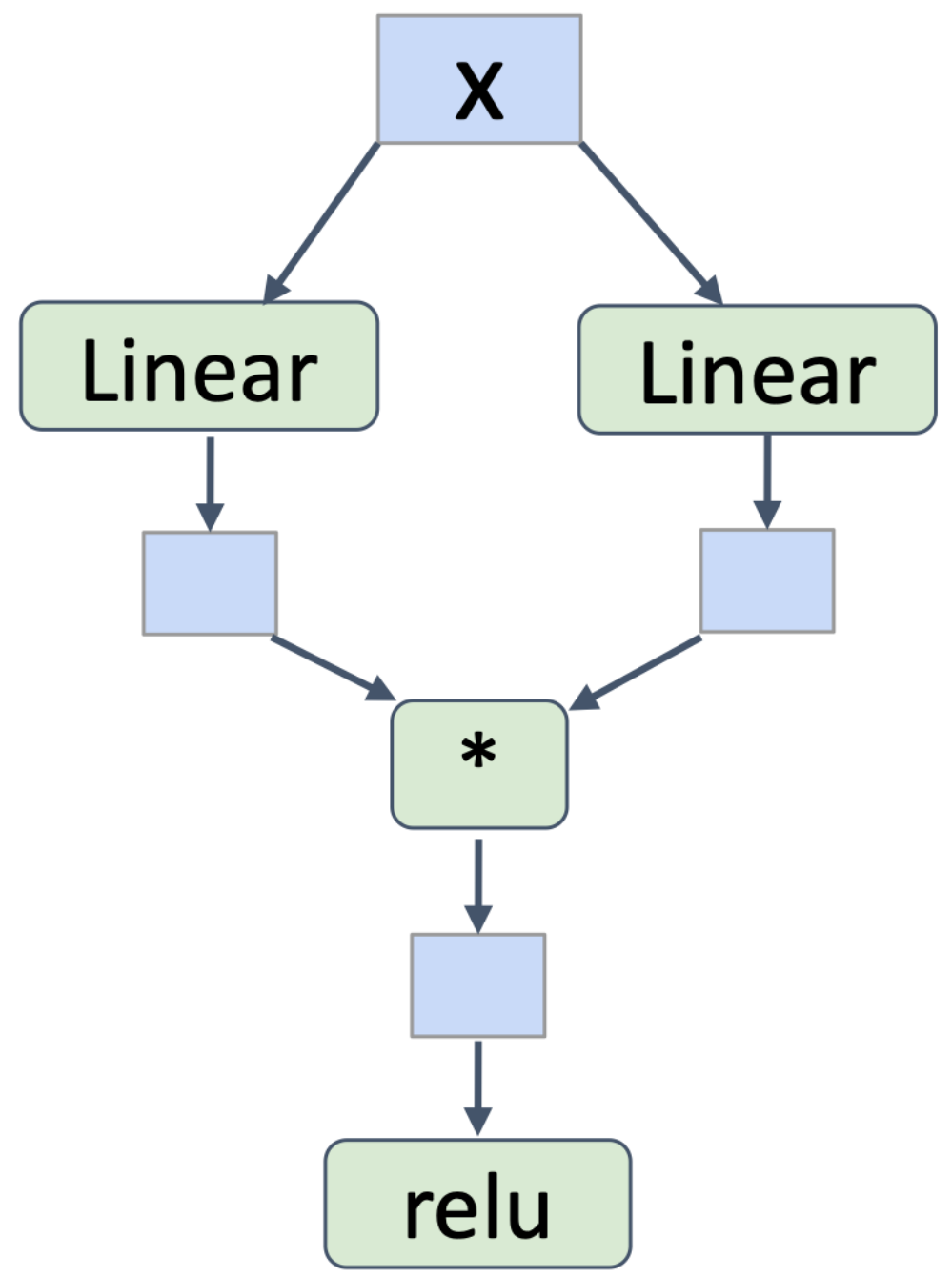

```
import torch

class ParallelBlock(torch.nn.Module):
    def __init__(self, D_in, D_out):
        super(ParallelBlock, self).__init__()
        self.linear1 = torch.nn.Linear(D_in, D_out)
        self.linear2 = torch.nn.Linear(D_in, D_out)

    def forward(self, x):
        h1 = self.linear1(x)
        h2 = self.linear2(x)
        return (h1 * h2).clamp(min=0)

N, D_in, H, D_out = 64, 1000, 100, 10
x = torch.randn(N, D_in)
y = torch.randn(N, D_out)

model = torch.nn.Sequential(
    ParallelBlock(D_in, H),
    ParallelBlock(H, H),
    torch.nn.Linear(H, D_out))

optimizer = torch.optim.Adam(model.parameters(), lr=1e-4)
for t in range(500):
    y_pred = model(x)
    loss = torch.nn.functional.mse_loss(y_pred, y)
    loss.backward()
    optimizer.step()
    optimizer.zero_grad()
```



# PyTorch: nn Defining Modules

Stack multiple instances of the component in a sequential

Very easy to quickly build complex network architectures!

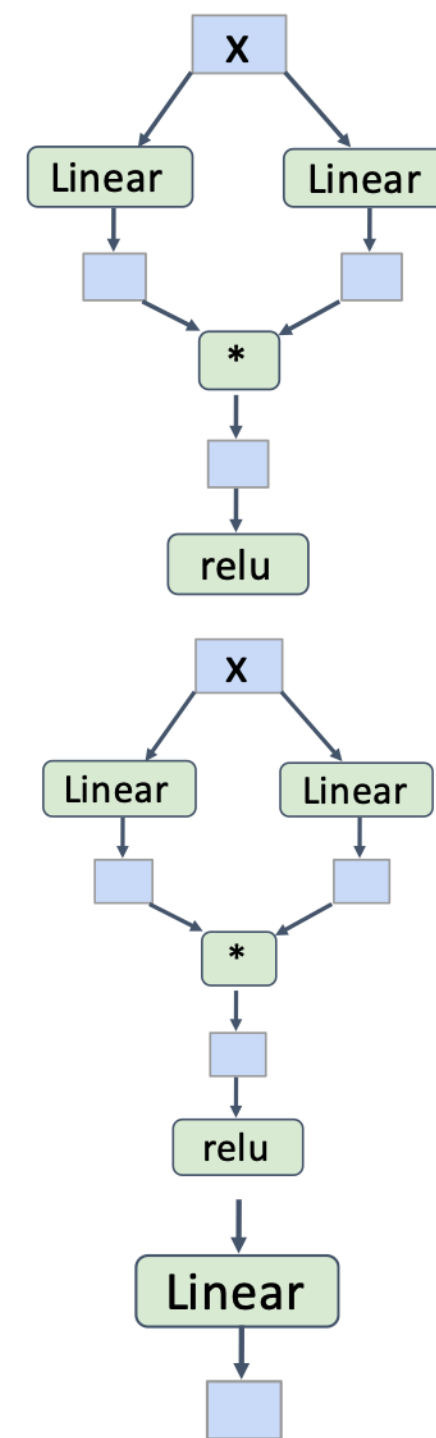

```
import torch

class ParallelBlock(torch.nn.Module):
    def __init__(self, D_in, D_out):
        super(ParallelBlock, self).__init__()
        self.linear1 = torch.nn.Linear(D_in, D_out)
        self.linear2 = torch.nn.Linear(D_in, D_out)

    def forward(self, x):
        h1 = self.linear1(x)
        h2 = self.linear2(x)
        return (h1 * h2).clamp(min=0)

N, D_in, H, D_out = 64, 1000, 100, 10
x = torch.randn(N, D_in)
y = torch.randn(N, D_out)

model = torch.nn.Sequential(
    ParallelBlock(D_in, H),
    ParallelBlock(H, H),
    torch.nn.Linear(H, D_out))

optimizer = torch.optim.Adam(model.parameters(), lr=1e-4)
for t in range(500):
    y_pred = model(x)
    loss = torch.nn.functional.mse_loss(y_pred, y)
    loss.backward()
    optimizer.step()
    optimizer.zero_grad()
```



# PyTorch: DataLoaders

A **DataLoader** wraps a **Dataset** and provides minibatching, shuffling, multithreading, for you

When you need to load custom data, just write your own Dataset class

```
import torch
from torch.utils.data import TensorDataset, DataLoader

N, D_in, H, D_out = 64, 1000, 100, 10
x = torch.randn(N, D_in)
y = torch.randn(N, D_out)

loader = DataLoader(TensorDataset(x, y), batch_size=8)
model = TwoLayerNet(D_in, H, D_out)

optimizer = torch.optim.SGD(model.parameters(), lr=1e-2)
for epoch in range(20):
    for x_batch, y_batch in loader:
        y_pred = model(x_batch)
        loss = torch.nn.functional.mse_loss(y_pred, y_batch)

        loss.backward()
        optimizer.step()
        optimizer.zero_grad()
```





# PyTorch: DataLoaders

Iterate over loader to form minibatches

```
import torch
from torch.utils.data import TensorDataset, DataLoader

N, D_in, H, D_out = 64, 1000, 100, 10
x = torch.randn(N, D_in)
y = torch.randn(N, D_out)

loader = DataLoader(TensorDataset(x, y), batch_size=8)
model = TwoLayerNet(D_in, H, D_out)

optimizer = torch.optim.SGD(model.parameters(), lr=1e-2)
for epoch in range(20):
    for x_batch, y_batch in loader:
        y_pred = model(x_batch)
        loss = torch.nn.functional.mse_loss(y_pred, y_batch)

        loss.backward()
        optimizer.step()
        optimizer.zero_grad()
```



# PyTorch: Pretrained Models

---

Super easy to use pretrained models with torch vision

<https://pytorch.org/vision/stable/>

```
import torch
import torchvision

alexnet = torchvision.models.alexnet(pretrained=True)
vgg16 = torchvision.models.vgg16(pretrained=True)
resnet101 = torchvision.models.resnet101(pretrained=True)
```



# PyTorch: Dynamic Computation Graphs

---

```
import torch

N, D_in, H, D_out = 64, 1000, 100, 10
x = torch.randn(N, D_in)
y = torch.randn(N, D_out)
w1 = torch.randn(D_in, H, requires_grad=True)
w2 = torch.randn(H, D_out, requires_grad=True)

learning_rate = 1e-6
for t in range(500):
    y_pred = x.mm(w1).clamp(min=0).mm(w2)
    loss = (y_pred - y).pow(2).sum()

    loss.backward()
```



# PyTorch: Dynamic Computation Graphs

x      w1      w2      y

```
import torch

N, D_in, H, D_out = 64, 1000, 100, 10
x = torch.randn(N, D_in)
y = torch.randn(N, D_out)
w1 = torch.randn(D_in, H, requires_grad=True)
w2 = torch.randn(H, D_out, requires_grad=True)

learning_rate = 1e-6
for t in range(500):
    y_pred = x.mm(w1).clamp(min=0).mm(w2)
    loss = (y_pred - y).pow(2).sum()

    loss.backward()
```

Create Tensor objects



# PyTorch: Dynamic Computation Graphs

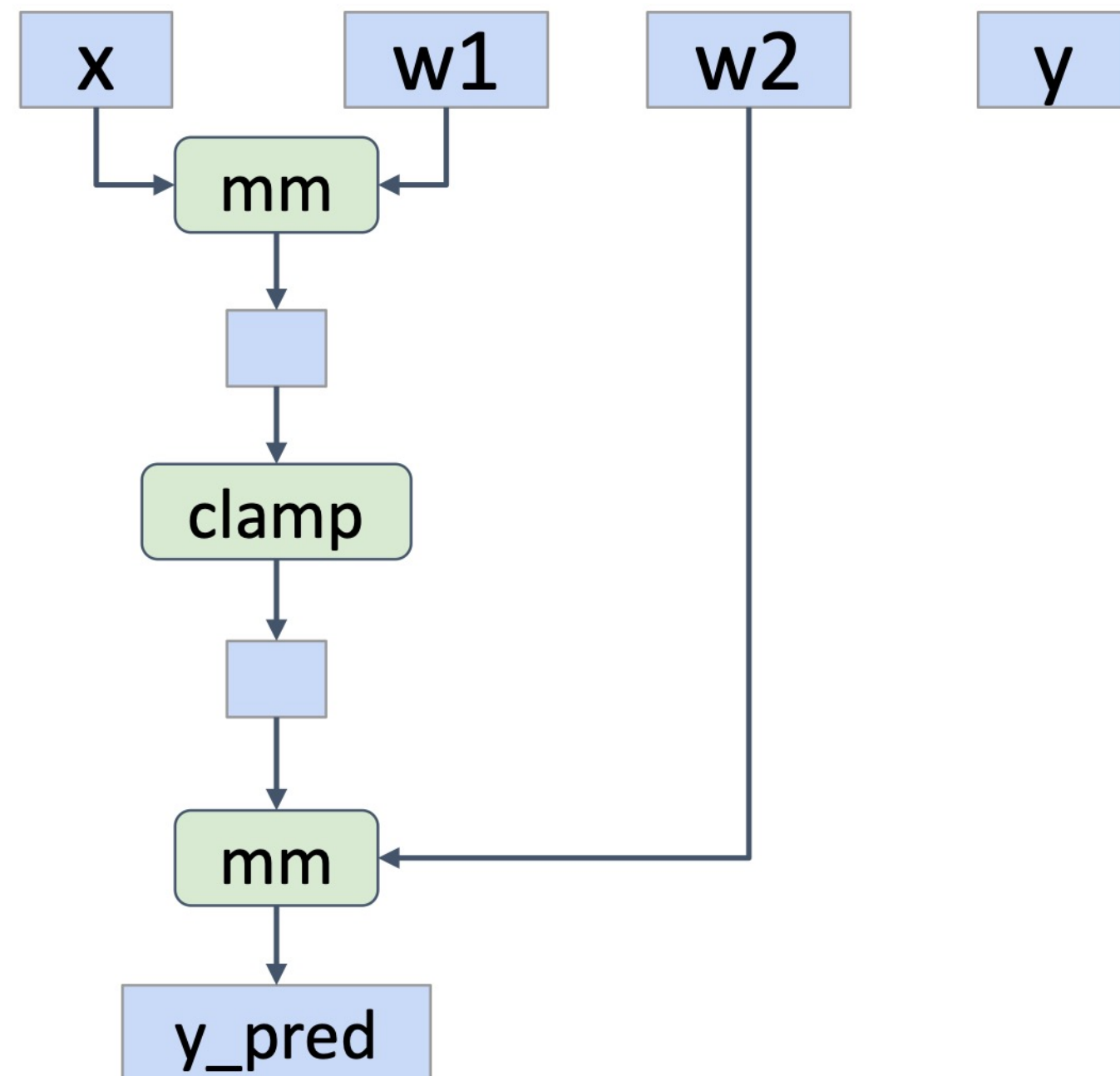

```
import torch

N, D_in, H, D_out = 64, 1000, 100, 10
x = torch.randn(N, D_in)
y = torch.randn(N, D_out)
w1 = torch.randn(D_in, H, requires_grad=True)
w2 = torch.randn(H, D_out, requires_grad=True)

learning_rate = 1e-6
for t in range(500):
    y_pred = x.mm(w1).clamp(min=0).mm(w2)
    loss = (y_pred - y).pow(2).sum()

    loss.backward()
```

Build graph data structure  
AND perform computation



# PyTorch: Dynamic Computation Graphs

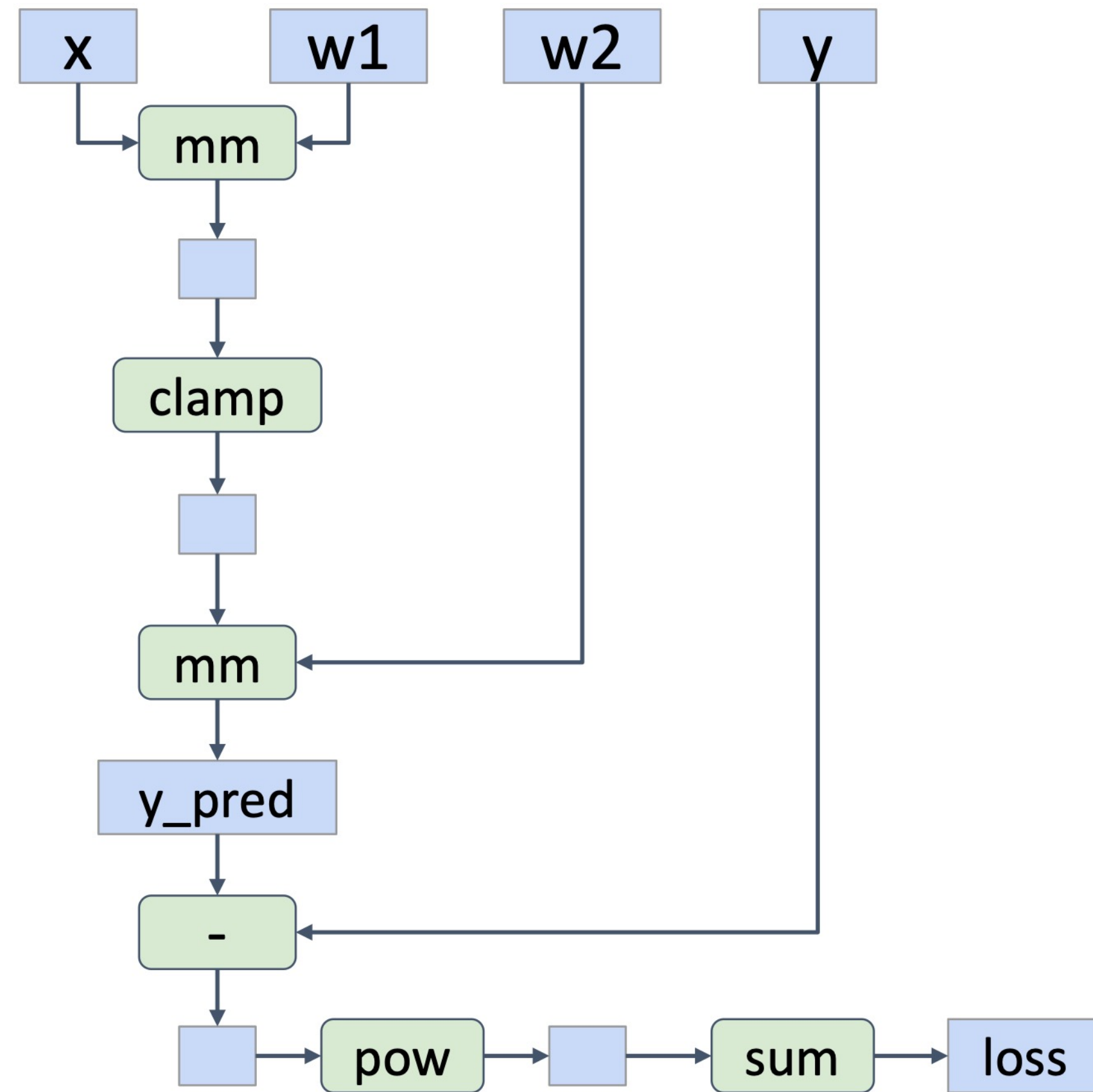

```
import torch

N, D_in, H, D_out = 64, 1000, 100, 10
x = torch.randn(N, D_in)
y = torch.randn(N, D_out)
w1 = torch.randn(D_in, H, requires_grad=True)
w2 = torch.randn(H, D_out, requires_grad=True)

learning_rate = 1e-6
for t in range(500):
    y_pred = x.mm(w1).clamp(min=0).mm(w2)
    loss = (y_pred - y).pow(2).sum()

    loss.backward()
```

Build graph data structure  
AND perform computation



# PyTorch: Dynamic Computation Graphs

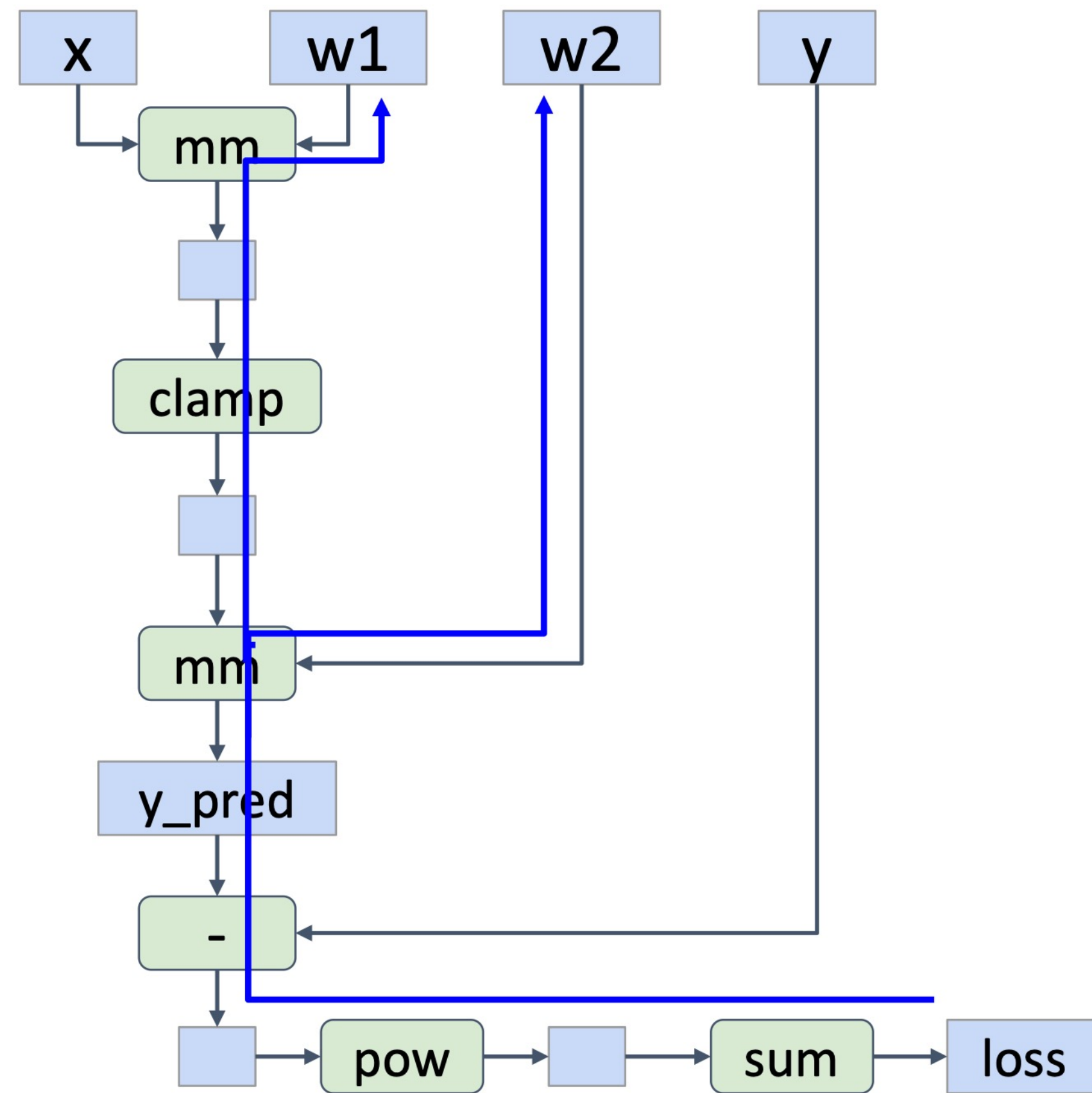

```
import torch

N, D_in, H, D_out = 64, 1000, 100, 10
x = torch.randn(N, D_in)
y = torch.randn(N, D_out)
w1 = torch.randn(D_in, H, requires_grad=True)
w2 = torch.randn(H, D_out, requires_grad=True)

learning_rate = 1e-6
for t in range(500):
    y_pred = x.mm(w1).clamp(min=0).mm(w2)
    loss = (y_pred - y).pow(2).sum()

    loss.backward()
```

Perform backprop,  
throw away graph



# PyTorch: Dynamic Computation Graphs



```
import torch

N, D_in, H, D_out = 64, 1000, 100, 10
x = torch.randn(N, D_in)
y = torch.randn(N, D_out)
w1 = torch.randn(D_in, H, requires_grad=True)
w2 = torch.randn(H, D_out, requires_grad=True)

learning_rate = 1e-6
for t in range(500):
    y_pred = x.mm(w1).clamp(min=0).mm(w2)
    loss = (y_pred - y).pow(2).sum()

    loss.backward()
```

Perform backprop,  
throw away graph





# PyTorch: Dynamic Computation Graphs

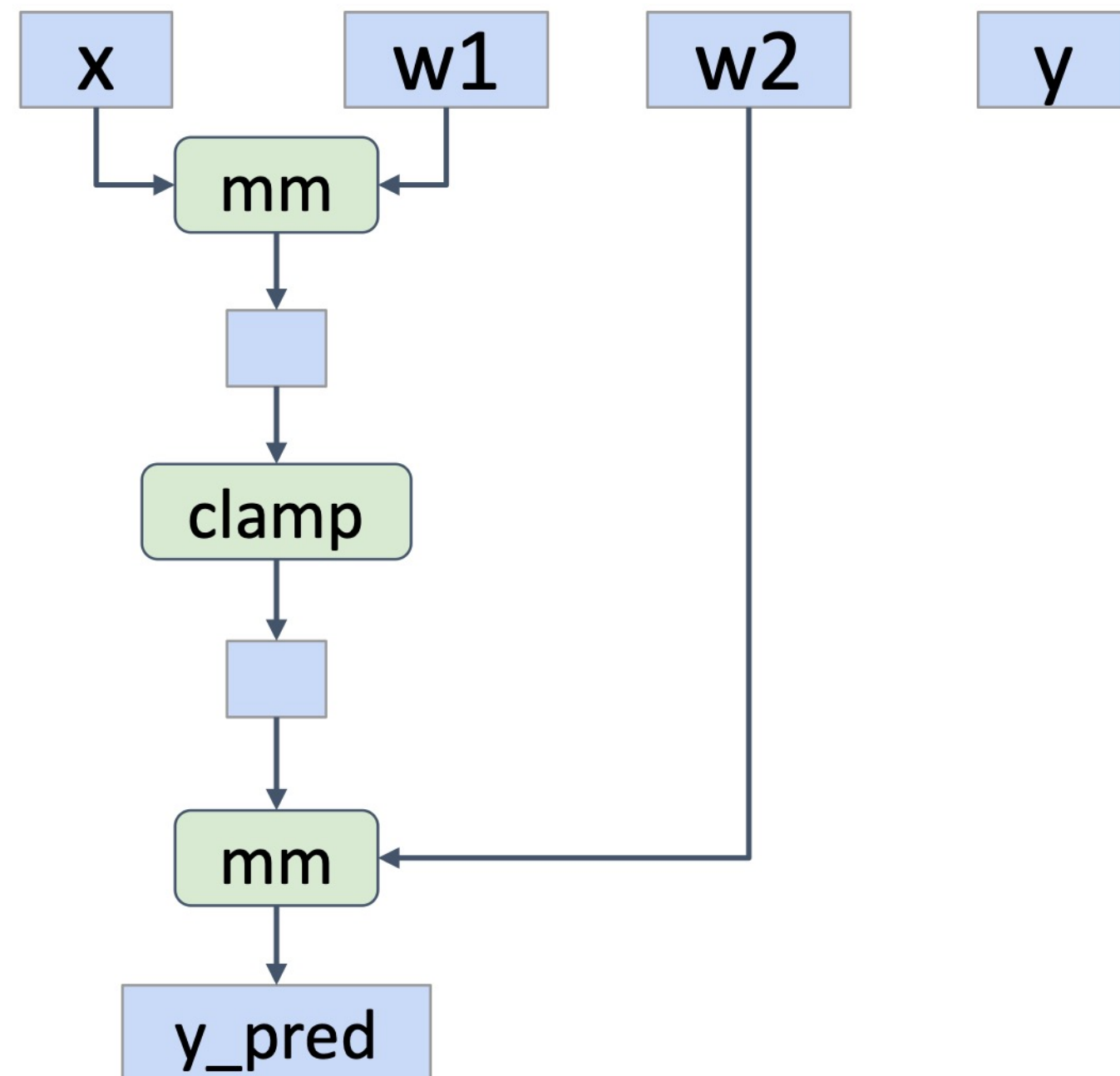

```
import torch

N, D_in, H, D_out = 64, 1000, 100, 10
x = torch.randn(N, D_in)
y = torch.randn(N, D_out)
w1 = torch.randn(D_in, H, requires_grad=True)
w2 = torch.randn(H, D_out, requires_grad=True)

learning_rate = 1e-6
for t in range(500):
    y_pred = x.mm(w1).clamp(min=0).mm(w2)
    loss = (y_pred - y).pow(2).sum()

    loss.backward()
```

Build graph data structure  
AND perform computation



# PyTorch: Dynamic Computation Graphs

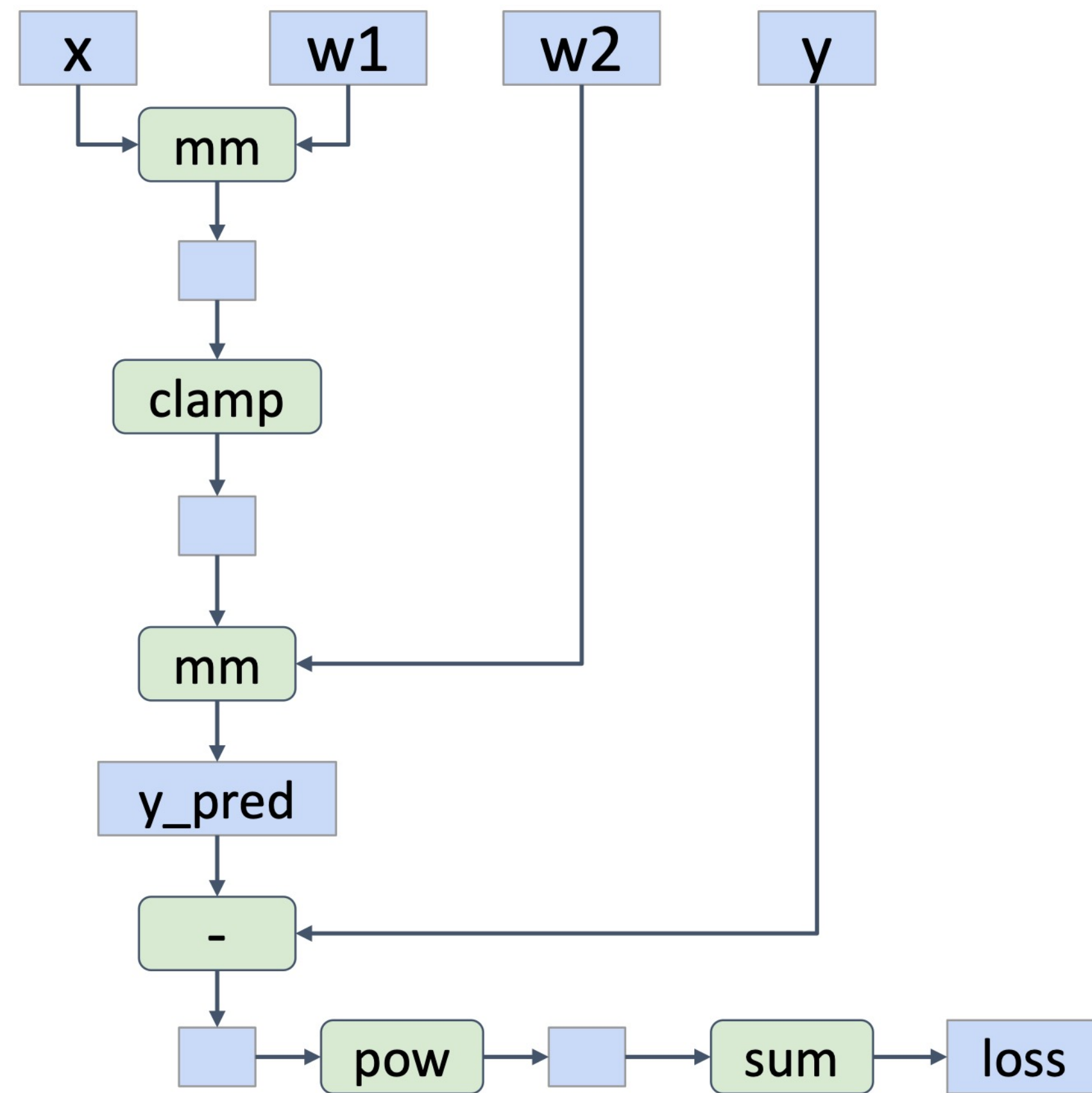

```
import torch

N, D_in, H, D_out = 64, 1000, 100, 10
x = torch.randn(N, D_in)
y = torch.randn(N, D_out)
w1 = torch.randn(D_in, H, requires_grad=True)
w2 = torch.randn(H, D_out, requires_grad=True)

learning_rate = 1e-6
for t in range(500):
    y_pred = x.mm(w1).clamp(min=0).mm(w2)
    loss = (y_pred - y).pow(2).sum()

    loss.backward()
```

Build graph data structure  
AND perform computation



# PyTorch: Dynamic Computation Graphs

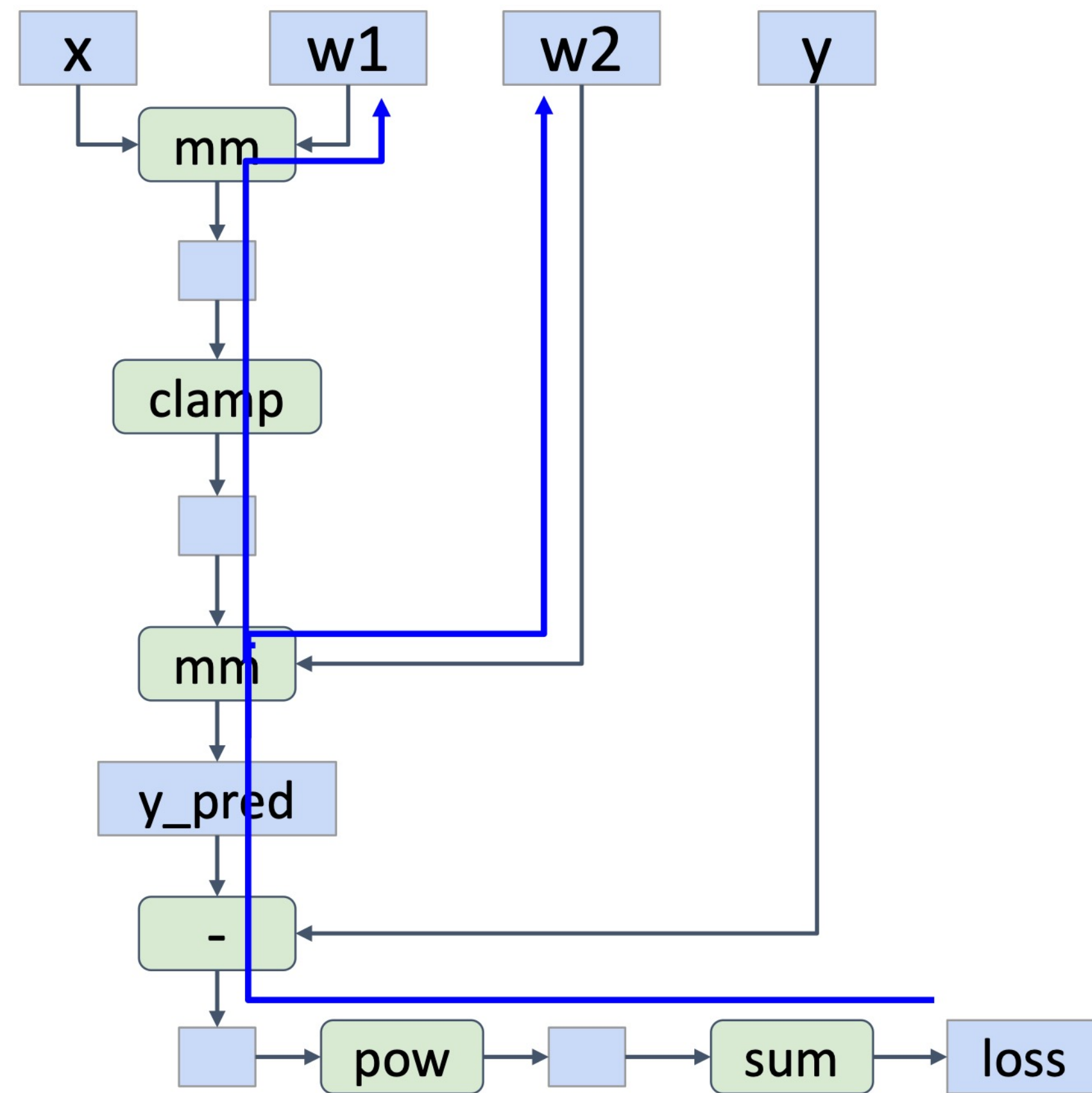

```
import torch
```

```
N, D_in, H, D_out = 64, 1000, 100, 10
```

```
x = torch.randn(N, D_in)
```

```
y = torch.randn(N, D_out)
```

```
w1 = torch.randn(D_in, H, requires_grad=True)
```

```
w2 = torch.randn(H, D_out, requires_grad=True)
```

```
learning_rate = 1e-6
```

```
for t in range(500):
```

```
    y_pred = x.mm(w1).clamp(min=0).mm(w2)
```

```
    loss = (y_pred - y).pow(2).sum()
```

```
    loss.backward()
```

Perform backprop,  
throw away graph



# PyTorch: Dynamic Computation Graphs

Dynamic graphs let you use regular Python control flow during the forward pass!

```
import torch

N, D_in, H, D_out = 64, 1000, 100, 10
x = torch.randn(N, D_in)
y = torch.randn(N, D_out)
w1 = torch.randn(D_in, H, requires_grad=True)
w2a = torch.randn(H, D_out, requires_grad=True)
w2b = torch.randn(H, D_out, requires_grad=True)

learning_rate = 1e-6
prev_loss = 5.0
for t in range(500):
    w2 = w2a if prev_loss < 5.0 else w2b
    y_pred = x.mm(w1).clamp(min=0).mm(w2)
    loss = (y_pred - y).pow(2).sum()

    loss.backward()
    prev_loss = loss.item()
```



# PyTorch: Dynamic Computation Graphs

Dynamic graphs let you use regular Python control flow during the forward pass!

Initialize two different weight matrices for second layer

```
import torch

N, D_in, H, D_out = 64, 1000, 100, 10
x = torch.randn(N, D_in)
y = torch.randn(N, D_out)
w1 = torch.randn(D_in, H, requires_grad=True)
w2a = torch.randn(H, D_out, requires_grad=True)
w2b = torch.randn(H, D_out, requires_grad=True)

learning_rate = 1e-6
prev_loss = 5.0
for t in range(500):
    w2 = w2a if prev_loss < 5.0 else w2b
    y_pred = x.mm(w1).clamp(min=0).mm(w2)
    loss = (y_pred - y).pow(2).sum()

    loss.backward()
    prev_loss = loss.item()
```



# PyTorch: Dynamic Computation Graphs

Dynamic graphs let you use regular Python control flow during the forward pass!

Decide which one to use at each layer based on loss at previous iteration

(this model doesn't make sense! Just a simple dynamic example)

```
import torch

N, D_in, H, D_out = 64, 1000, 100, 10
x = torch.randn(N, D_in)
y = torch.randn(N, D_out)
w1 = torch.randn(D_in, H, requires_grad=True)
w2a = torch.randn(H, D_out, requires_grad=True)
w2b = torch.randn(H, D_out, requires_grad=True)

learning_rate = 1e-6
prev_loss = 5.0
for t in range(500):
    w2 = w2a if prev_loss < 5.0 else w2b
    y_pred = x.mm(w1).clamp(min=0).mm(w2)
    loss = (y_pred - y).pow(2).sum()

    loss.backward()
    prev_loss = loss.item()
```



w2 = w2a if prev\_loss < 5.0 else w2b



# Alternative: Static Computation Graphs

Alternative: **Static** graphs

Step 1: Build computational graph describing our computation (including finding paths for backprop)

Step 2: Reuse the same graph on every iteration

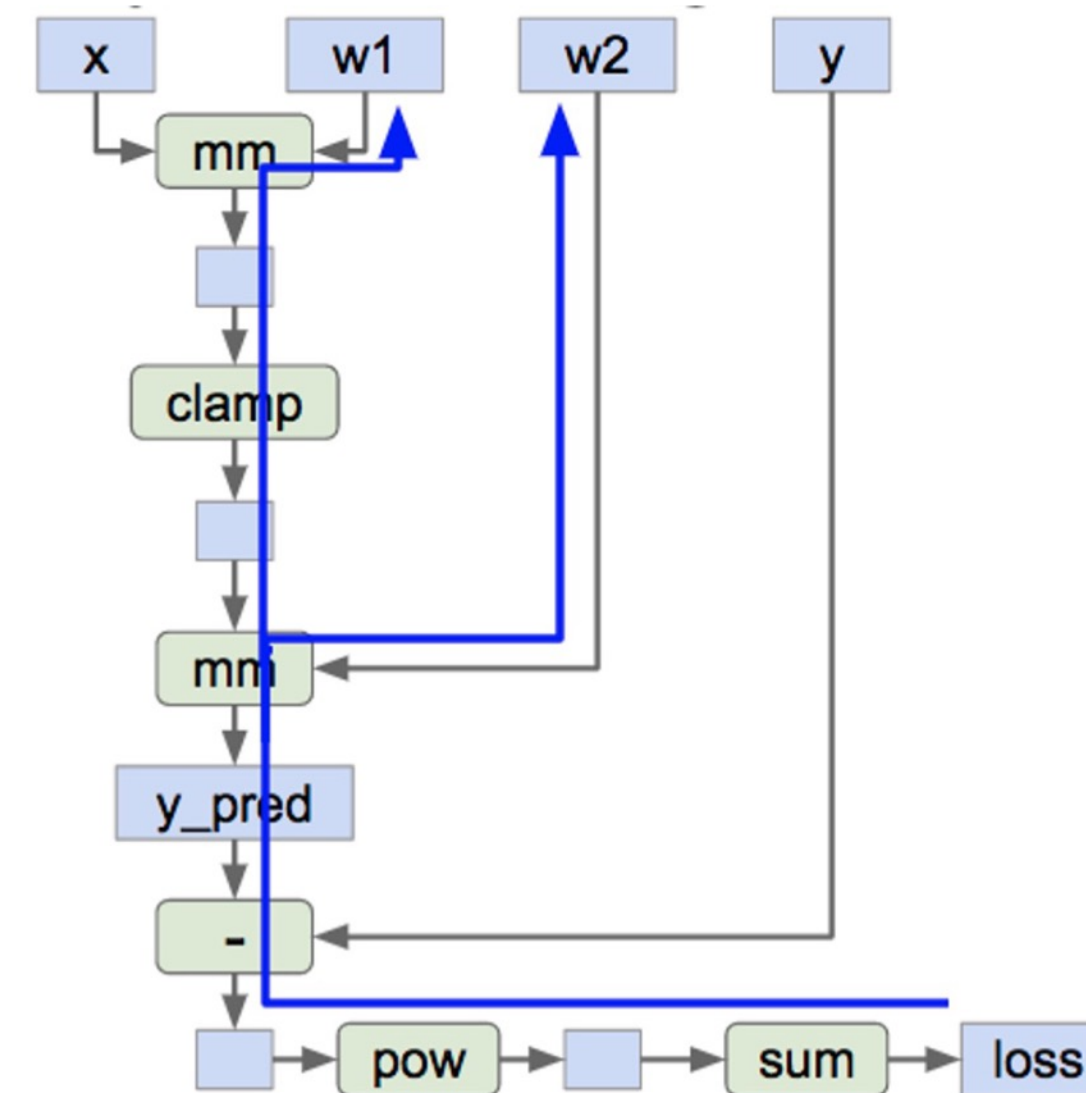

```
graph = build_graph()  
  
for x_batch, y_batch in loader:  
    run_graph(graph, x=x_batch, y=y_batch)
```



# Alternative: Static Graphs with JIT

Define model as a Python function

```
import torch
```

```
def model(x, y, w1, w2a, w2b, prev_loss):  
    w2 = w2a if prev_loss < 5.0 else w2b  
    y_pred = x.mm(w1).clamp(min=0).mm(w2)  
    loss = (y_pred - y).pow(2).sum()  
    return loss
```

```
N, D_in, H, D_out = 64, 1000, 100, 10  
x = torch.randn(N, D_in)  
y = torch.randn(N, D_out)  
w1 = torch.randn(D_in, H, requires_grad=True)  
w2a = torch.randn(H, D_out, requires_grad=True)  
w2b = torch.randn(H, D_out, requires_grad=True)
```

```
graph = torch.jit.script(model)
```

```
prev_loss = 5.0  
learning_rate = 1e-6  
for t in range(500):  
    loss = graph(x, y, w1, w2a, w2b, prev_loss)
```

```
    loss.backward()  
    prev_loss = loss.item()
```





# Alternative: Static Graphs with JIT

Just-In-Time compilation:  
Introspect the source code  
of the function, **compile** it  
into a graph object.

Lots of magic here!

```
import torch

def model(x, y, w1, w2a, w2b, prev_loss):
    w2 = w2a if prev_loss < 5.0 else w2b
    y_pred = x.mm(w1).clamp(min=0).mm(w2)
    loss = (y_pred - y).pow(2).sum()
    return loss

N, D_in, H, D_out = 64, 1000, 100, 10
x = torch.randn(N, D_in)
y = torch.randn(N, D_out)
w1 = torch.randn(D_in, H, requires_grad=True)
w2a = torch.randn(H, D_out, requires_grad=True)
w2b = torch.randn(H, D_out, requires_grad=True)

graph = torch.jit.script(model)

prev_loss = 5.0
learning_rate = 1e-6
for t in range(500):
    loss = graph(x, y, w1, w2a, w2b, prev_loss)

    loss.backward()
    prev_loss = loss.item()
```



# Alternative: Static Graphs with JIT

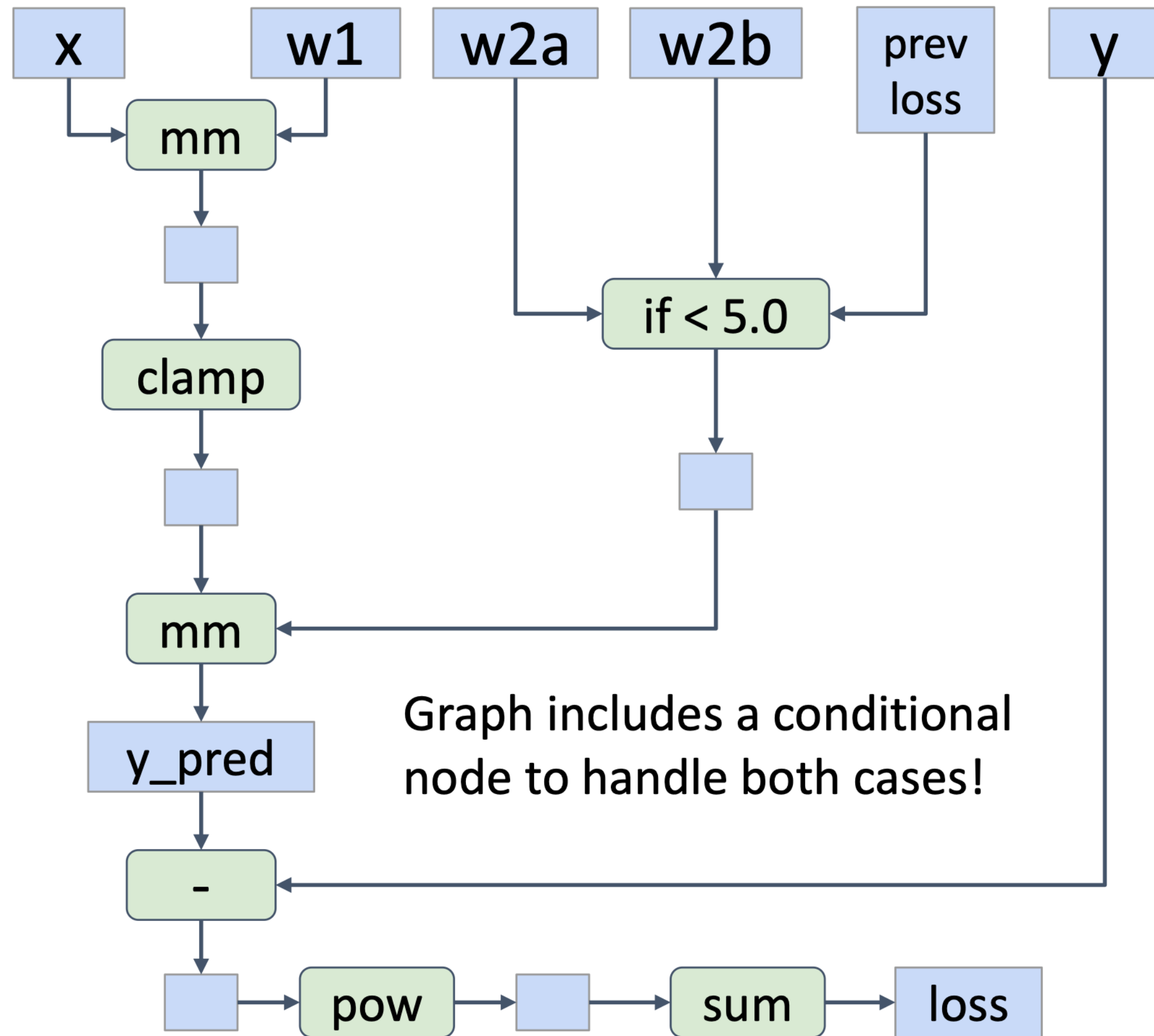

```
import torch
```

```
def model(x, y, w1, w2a, w2b, prev_loss):  
    w2 = w2a if prev_loss < 5.0 else w2b  
    y_pred = x.mm(w1).clamp(min=0).mm(w2)  
    loss = (y_pred - y).pow(2).sum()  
    return loss
```

```
N, D_in, H, D_out = 64, 1000, 100, 10
```

```
x = torch.randn(N, D_in)
```

```
y = torch.randn(N, D_out)
```

```
w1 = torch.randn(D_in, H, requires_grad=True)
```

```
w2a = torch.randn(H, D_out, requires_grad=True)
```

```
w2b = torch.randn(H, D_out, requires_grad=True)
```

```
graph = torch.jit.script(model)
```

```
prev_loss = 5.0
```

```
learning_rate = 1e-6
```

```
for t in range(500):
```

```
    loss = graph(x, y, w1, w2a, w2b, prev_loss).
```

```
    loss.backward()
```

```
    prev_loss = loss.item()
```



# Alternative: Static Graphs with JIT

Use our compiled graph object at each forward pass

```
import torch

def model(x, y, w1, w2a, w2b, prev_loss):
    w2 = w2a if prev_loss < 5.0 else w2b
    y_pred = x.mm(w1).clamp(min=0).mm(w2)
    loss = (y_pred - y).pow(2).sum()
    return loss

N, D_in, H, D_out = 64, 1000, 100, 10
x = torch.randn(N, D_in)
y = torch.randn(N, D_out)
w1 = torch.randn(D_in, H, requires_grad=True)
w2a = torch.randn(H, D_out, requires_grad=True)
w2b = torch.randn(H, D_out, requires_grad=True)

graph = torch.jit.script(model)

prev_loss = 5.0
learning_rate = 1e-6
for t in range(500):
    loss = graph(x, y, w1, w2a, w2b, prev_loss)

    loss.backward()
    prev_loss = loss.item()
```



# Alternative: Static Graphs with JIT

Even easier: add **annotation** to function, Python function compiled to a graph when it is defined

Calling function uses graph

```
import torch

@torch.jit.script
def model(x, y, w1, w2a, w2b, prev_loss):
    w2 = w2a if prev_loss < 5.0 else w2b
    y_pred = x.mm(w1).clamp(min=0).mm(w2)
    loss = (y_pred - y).pow(2).sum()
    return loss

N, D_in, H, D_out = 64, 1000, 100, 10
x = torch.randn(N, D_in)
y = torch.randn(N, D_out)
w1 = torch.randn(D_in, H, requires_grad=True)
w2a = torch.randn(H, D_out, requires_grad=True)
w2b = torch.randn(H, D_out, requires_grad=True)

prev_loss = 5.0
learning_rate = 1e-6
for t in range(500):
    loss = model(x, y, w1, w2a, w2b, prev_loss)

    loss.backward()
    prev_loss = loss.item()
```



# Static vs Dynamic Graphs: Optimization

With static graphs, framework can **optimize** the graph for you before it runs!

The graph you wrote

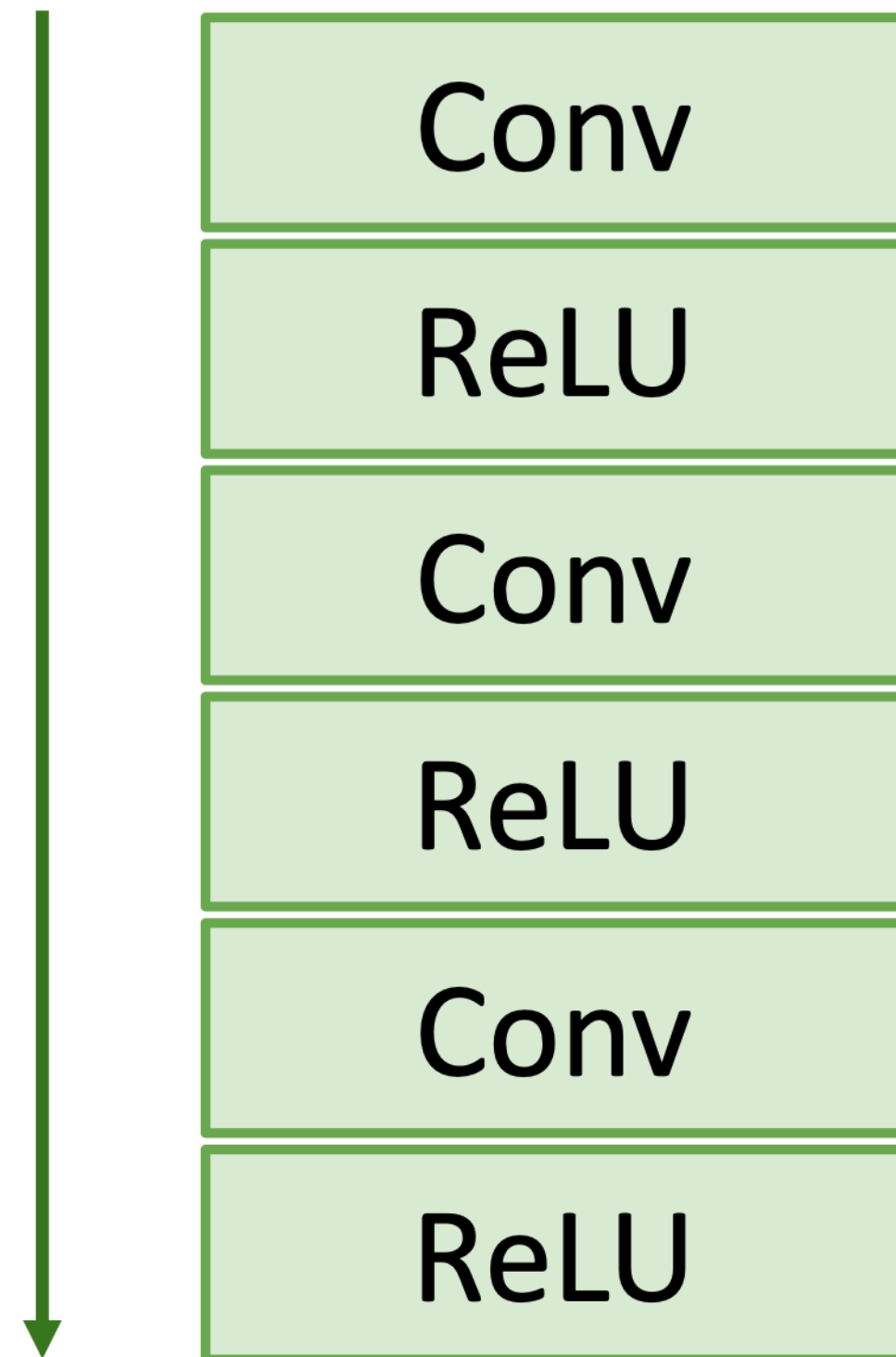

Equivalent graph with **fused operations**

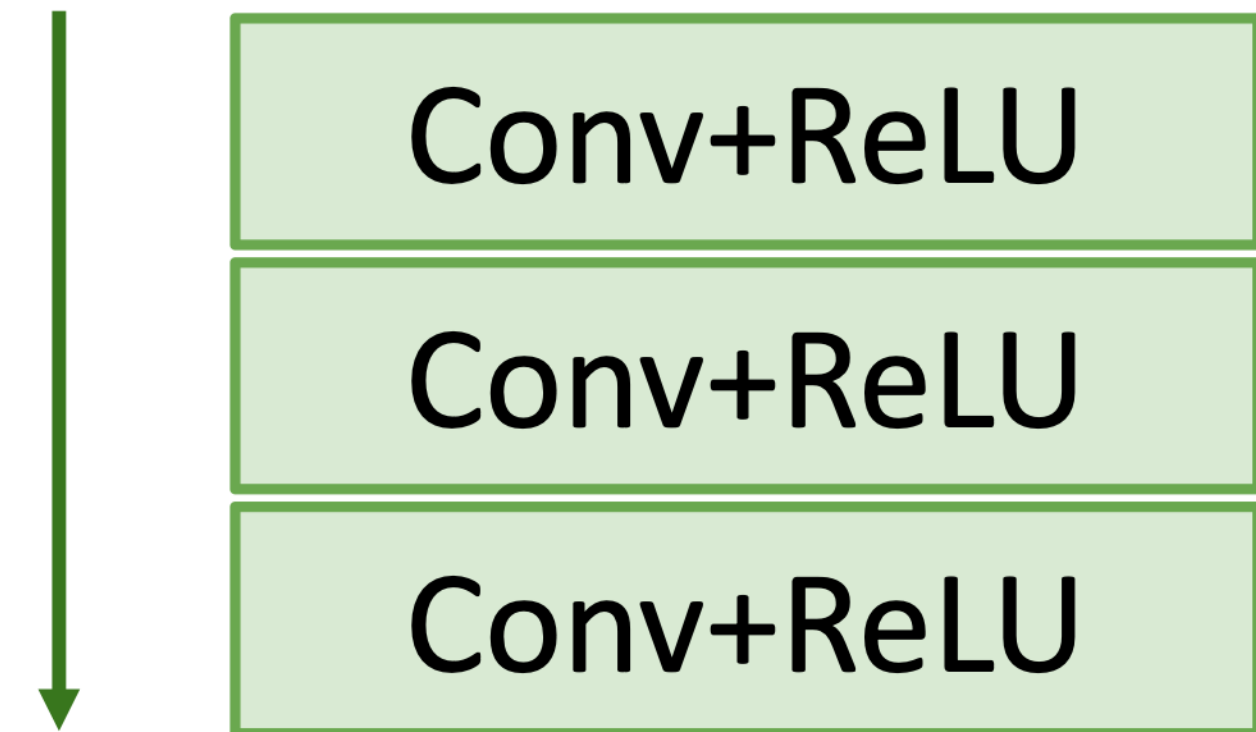



# Static vs Dynamic Graphs: Optimization

---

## Static

Once graph is built, can **serialize** it and run it without the code that built the graph!

e.g. train model in Python, deploy in C++

## Dynamic

Graph building and execution are intertwined, so always need to keep code around



# Static vs Dynamic Graphs: Optimization

---

## Static

Lots of indirection between the code you write and the code that runs – can be hard to debug, benchmark, etc

## Dynamic

The code you write is the code that runs! Easy to reason about, debug, profile, etc



# Dynamic Graph Applications

Model structure depends on the input:

- Recurrent Networks
- Recursive Networks

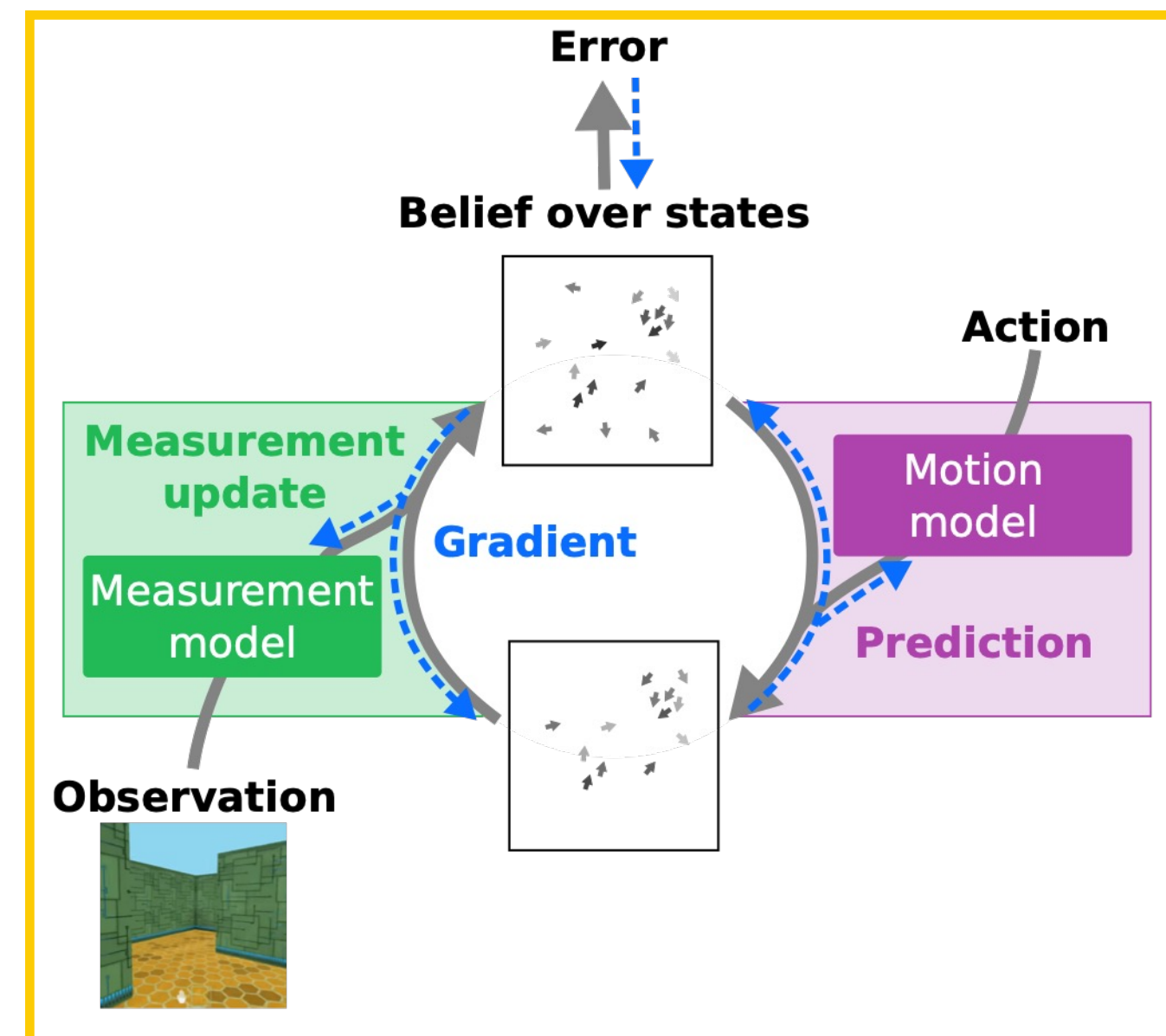

[1] Ma et al., RSS 2018

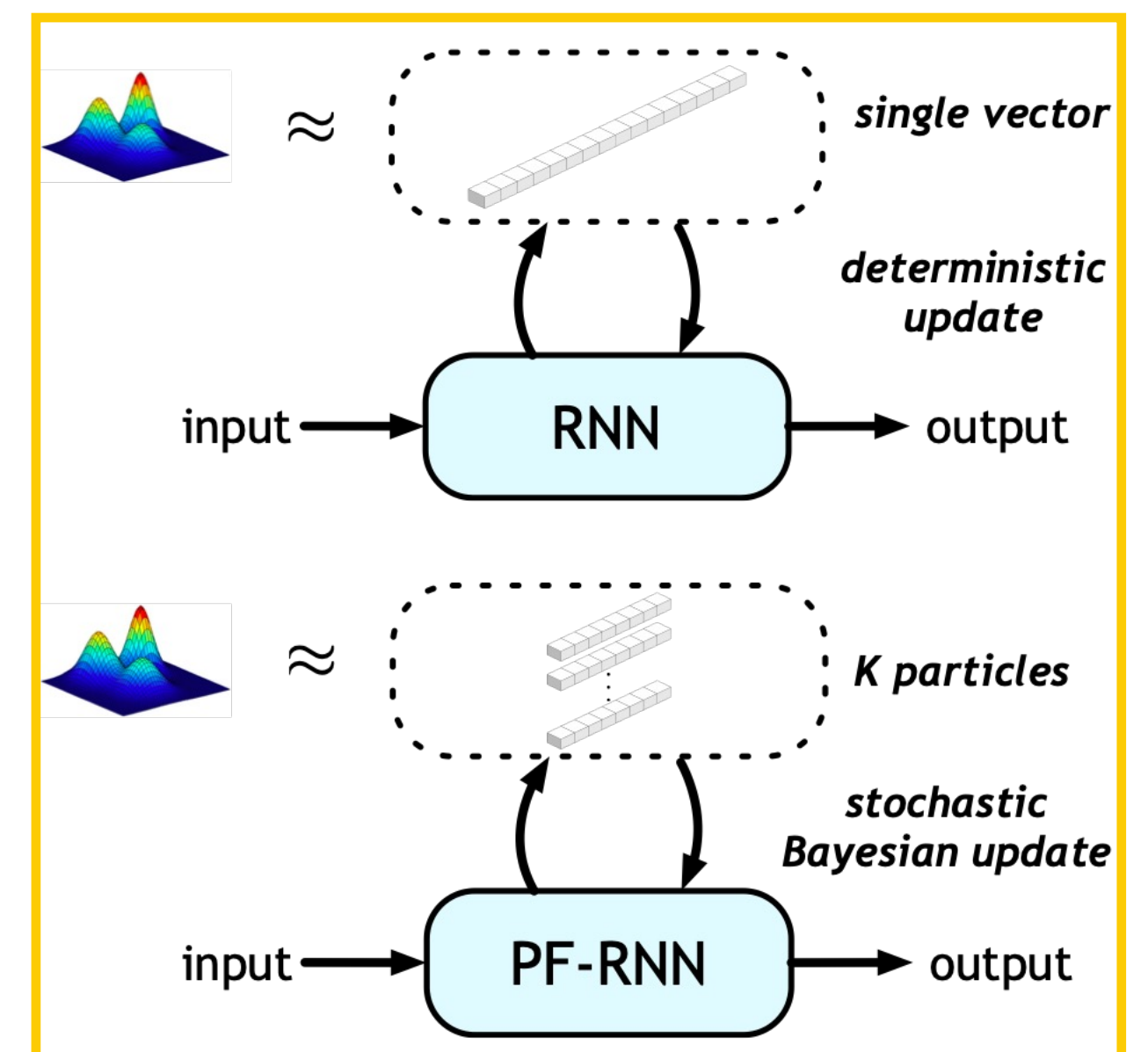

[2] Ma et al., AAI 2020





# Dynamic Graph Applications

Model structure depends on the input:

- Recurrent Networks
- Recursive Networks
- Modular Networks

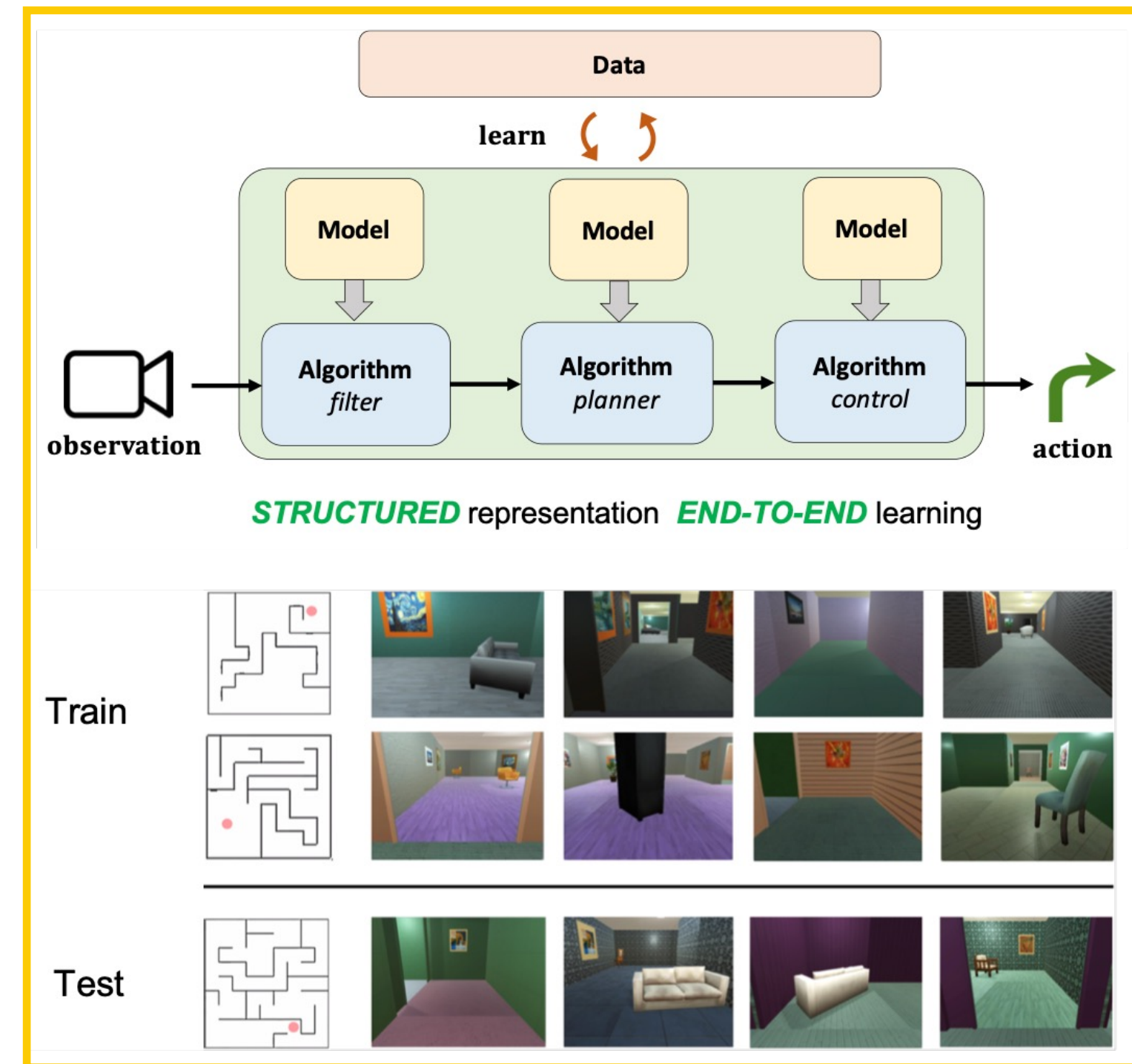

[1] Karkus et al., RSS 2019



# Dynamic Graph Applications

---

Model structure  
depends on the input:

- Recurrent Networks
- Recursive Networks
- Modular Networks
- (Your idea here!)

**Final Project**



# TensorFlow: Versions

---

## TensorFlow 1.0

- Final release: 1.15.3
- Default: **static graphs**
- Optional: dynamic graphs (eager mode)

## TensorFlow 2.0

- Current release: 2.8.0
  - Released 2/2/2022
- Default: **dynamic graphs**
- Optional: static graphs



# TensorFlow 1.0: Static Graphs

```
import numpy as np
import tensorflow as tf
```

(Assume imports at the top of each snippet)

```
N, D, H = 64, 1000, 100
x = tf.placeholder(tf.float32, shape=(N, D))
y = tf.placeholder(tf.float32, shape=(N, D))
w1 = tf.placeholder(tf.float32, shape=(D, H))
w2 = tf.placeholder(tf.float32, shape=(H, D))

h = tf.maximum(tf.matmul(x, w1), 0)
y_pred = tf.matmul(h, w2)
diff = y_pred - y
loss = tf.reduce_mean(tf.reduce_sum(diff ** 2, axis=1))

grad_w1, grad_w2 = tf.gradients(loss, [w1, w2])

with tf.Session() as sess:
    values = {x: np.random.randn(N, D),
              w1: np.random.randn(D, H),
              w2: np.random.randn(H, D),
              y: np.random.randn(N, D),}
    out = sess.run([loss, grad_w1, grad_w2],
                    feed_dict=values)
    loss_val, grad_w1_val, grad_w2_val = out
```



# TensorFlow 1.0: Static Graphs

First **define** computational graph



```
N, D, H = 64, 1000, 100
x = tf.placeholder(tf.float32, shape=(N, D))
y = tf.placeholder(tf.float32, shape=(N, D))
w1 = tf.placeholder(tf.float32, shape=(D, H))
w2 = tf.placeholder(tf.float32, shape=(H, D))

h = tf.maximum(tf.matmul(x, w1), 0)
y_pred = tf.matmul(h, w2)
diff = y_pred - y
loss = tf.reduce_mean(tf.reduce_sum(diff ** 2, axis=1))

grad_w1, grad_w2 = tf.gradients(loss, [w1, w2])
```

Then **run** the graph many times



```
with tf.Session() as sess:
    values = {x: np.random.randn(N, D),
              w1: np.random.randn(D, H),
              w2: np.random.randn(H, D),
              y: np.random.randn(N, D),}
    out = sess.run([loss, grad_w1, grad_w2],
                    feed_dict=values)
    loss_val, grad_w1_val, grad_w2_val = out
```



# TensorFlow 2.0: Dynamic Graphs

Create TensorFlow  
Tensors for data and  
weights

Weights need to be  
wrapped in `tf.Variable`  
so we can mutate them

```
import tensorflow as tf

N, Din, H, Dout = 16, 1000, 100, 10

x = tf.random.normal((N, Din))
y = tf.random.normal((N, Dout))
w1 = tf.Variable(tf.random.normal((Din, H)))
w2 = tf.Variable(tf.random.normal((H, Dout)))

learning_rate = 1e-6
for t in range(1000):
    with tf.GradientTape() as tape:
        h = tf.maximum(tf.matmul(x, w1), 0)
        y_pred = tf.matmul(h, w2)
        diff = y_pred - y
        loss = tf.reduce_mean(tf.reduce_sum(diff ** 2, axis=1))

    grad_w1, grad_w2 = tape.gradient(loss, [w1, w2])

    w1.assign(w1 - learning_rate * grad_w1)
    w2.assign(w2 - learning_rate * grad_w2)
```



# TensorFlow 2.0: Dynamic Graphs

Scope forward pass  
under a GradientTape to  
tell TensorFlow to start  
building a graph

```
import tensorflow as tf

N, Din, H, Dout = 16, 1000, 100, 10

x = tf.random.normal((N, Din))
y = tf.random.normal((N, Dout))
w1 = tf.Variable(tf.random.normal((Din, H)))
w2 = tf.Variable(tf.random.normal((H, Dout)))

learning_rate = 1e-6
for t in range(1000):
    with tf.GradientTape() as tape:
        h = tf.maximum(tf.matmul(x, w1), 0)
        y_pred = tf.matmul(h, w2)
        diff = y_pred - y
        loss = tf.reduce_mean(tf.reduce_sum(diff ** 2, axis=1))

    grad_w1, grad_w2 = tape.gradient(loss, [w1, w2])

    w1.assign(w1 - learning_rate * grad_w1)
    w2.assign(w2 - learning_rate * grad_w2)
```



# TensorFlow 2.0: Dynamic Graphs

Scope forward pass under a GradientTape to tell TensorFlow to start building a graph

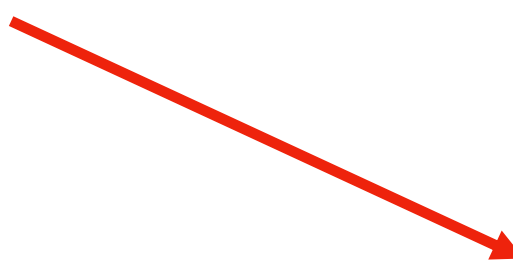

```
import tensorflow as tf

N, Din, H, Dout = 16, 1000, 100, 10

x = tf.random.normal((N, Din))
y = tf.random.normal((N, Dout))
w1 = tf.Variable(tf.random.normal((Din, H)))
w2 = tf.Variable(tf.random.normal((H, Dout)))

learning_rate = 1e-6
for t in range(1000):
    with tf.GradientTape() as tape:
        h = tf.maximum(tf.matmul(x, w1), 0)
        y_pred = tf.matmul(h, w2)
        diff = y_pred - y
        loss = tf.reduce_mean(tf.reduce_sum(diff ** 2, axis=1))

    grad_w1, grad_w2 = tape.gradient(loss, [w1, w2])

    w1.assign(w1 - learning_rate * grad_w1)
    w2.assign(w2 - learning_rate * grad_w2)
```

In PyTorch, all ops build graph by default; **opt out** via torch.no\_grad  
In Tensorflow, ops do not build graph by default; **opt in** via GradientTape





# TensorFlow 2.0: Dynamic Graphs

Ask the tape to  
compute gradients

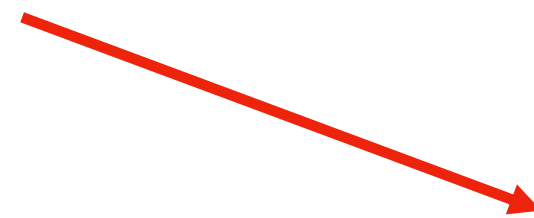

```
import tensorflow as tf

N, Din, H, Dout = 16, 1000, 100, 10

x = tf.random.normal((N, Din))
y = tf.random.normal((N, Dout))
w1 = tf.Variable(tf.random.normal((Din, H)))
w2 = tf.Variable(tf.random.normal((H, Dout)))

learning_rate = 1e-6
for t in range(1000):
    with tf.GradientTape() as tape:
        h = tf.maximum(tf.matmul(x, w1), 0)
        y_pred = tf.matmul(h, w2)
        diff = y_pred - y
        loss = tf.reduce_mean(tf.reduce_sum(diff ** 2, axis=1))

    grad_w1, grad_w2 = tape.gradient(loss, [w1, w2])

    w1.assign(w1 - learning_rate * grad_w1)
    w2.assign(w2 - learning_rate * grad_w2)
```



# TensorFlow 2.0: Dynamic Graphs

Gradient descent  
step, update weights

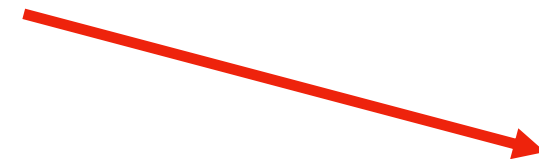

```
import tensorflow as tf

N, Din, H, Dout = 16, 1000, 100, 10

x = tf.random.normal((N, Din))
y = tf.random.normal((N, Dout))
w1 = tf.Variable(tf.random.normal((Din, H)))
w2 = tf.Variable(tf.random.normal((H, Dout)))

learning_rate = 1e-6
for t in range(1000):
    with tf.GradientTape() as tape:
        h = tf.maximum(tf.matmul(x, w1), 0)
        y_pred = tf.matmul(h, w2)
        diff = y_pred - y
        loss = tf.reduce_mean(tf.reduce_sum(diff ** 2, axis=1))

    grad_w1, grad_w2 = tape.gradient(loss, [w1, w2])

    w1.assign(w1 - learning_rate * grad_w1)
    w2.assign(w2 - learning_rate * grad_w2)
```



# TensorFlow 2.0: Static Graphs

Define a function that implements forward, backward, and update

Annotating with `tf.function` will compile the function into a graph! (similar to `torch.jit.script`)

```
@tf.function
def step(x, y, w1, w2):
    with tf.GradientTape() as tape:
        h = tf.maximum(tf.matmul(x, w1), 0)
        y_pred = tf.matmul(h, w2)
        diff = y_pred - y
        loss = tf.reduce_mean(tf.reduce_sum(diff ** 2, axis=1))

    grad_w1, grad_w2 = tape.gradient(loss, [w1, w2])

    w1.assign(w1 - learning_rate * grad_w1)
    w2.assign(w2 - learning_rate * grad_w2)
    return loss
```

```
N, Din, H, Dout = 16, 1000, 100, 10
```

```
x = tf.random.normal((N, Din))
y = tf.random.normal((N, Dout))
w1 = tf.Variable(tf.random.normal((Din, H)))
w2 = tf.Variable(tf.random.normal((H, Dout)))
```

```
learning_rate = 1e-6
for t in range(1000):
    loss = step(x, y, w1, w2)
```



# TensorFlow 2.0: Static Graphs

Define a function that implements forward, backward, and update

Annotating with `tf.function` will compile the function into a graph! (similar to `torch.jit.script`)

(note TF graph can include gradient computation and update, unlike PyTorch)

```
@tf.function
def step(x, y, w1, w2):
    with tf.GradientTape() as tape:
        h = tf.maximum(tf.matmul(x, w1), 0)
        y_pred = tf.matmul(h, w2)
        diff = y_pred - y
        loss = tf.reduce_mean(tf.reduce_sum(diff ** 2, axis=1))

    grad_w1, grad_w2 = tape.gradient(loss, [w1, w2])

    w1.assign(w1 - learning_rate * grad_w1)
    w2.assign(w2 - learning_rate * grad_w2)
    return loss

N, Din, H, Dout = 16, 1000, 100, 10

x = tf.random.normal((N, Din))
y = tf.random.normal((N, Dout))
w1 = tf.Variable(tf.random.normal((Din, H)))
w2 = tf.Variable(tf.random.normal((H, Dout)))

learning_rate = 1e-6
for t in range(1000):
    loss = step(x, y, w1, w2)
```

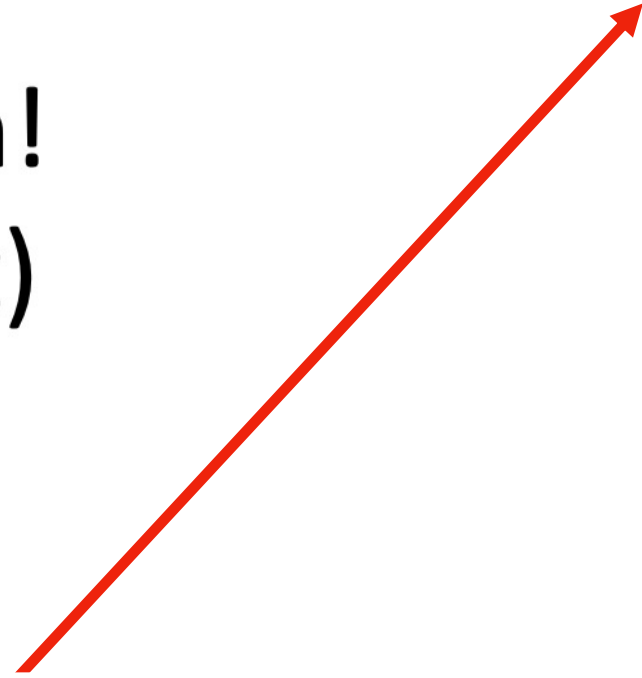



# TensorFlow 2.0: Static Graphs

Call the compiled step function in the training loop

```
@tf.function
def step(x, y, w1, w2):
    with tf.GradientTape() as tape:
        h = tf.maximum(tf.matmul(x, w1), 0)
        y_pred = tf.matmul(h, w2)
        diff = y_pred - y
        loss = tf.reduce_mean(tf.reduce_sum(diff ** 2, axis=1))

    grad_w1, grad_w2 = tape.gradient(loss, [w1, w2])

    w1.assign(w1 - learning_rate * grad_w1)
    w2.assign(w2 - learning_rate * grad_w2)
    return loss

N, Din, H, Dout = 16, 1000, 100, 10

x = tf.random.normal((N, Din))
y = tf.random.normal((N, Dout))
w1 = tf.Variable(tf.random.normal((Din, H)))
w2 = tf.Variable(tf.random.normal((H, Dout)))

learning_rate = 1e-6
for t in range(1000):
    loss = step(x, y, w1, w2)
```



# Keras: High-level API

```
import tensorflow as tf
from tensorflow.keras.models import Sequential
from tensorflow.keras.layers import InputLayer, Dense

N, Din, H, Dout = 16, 1000, 100, 10

model = Sequential()
model.add(InputLayer(input_shape=(Din,)))
model.add(Dense(units=H, activation='relu'))
model.add(Dense(units=Dout))
params = model.trainable_variables

loss_fn = tf.keras.losses.MeanSquaredError()
opt = tf.keras.optimizers.SGD(learning_rate=1e-6)

x = tf.random.normal((N, Din))
y = tf.random.normal((N, Dout))

for t in range(1000):
    with tf.GradientTape() as tape:
        y_pred = model(x)
        loss = loss_fn(y_pred, y)
        grads = tape.gradient(loss, params)
        opt.apply_gradients(zip(grads, params))
```



# Keras: High-level API

Object-oriented API:  
build the model as a  
stack of layers

```
import tensorflow as tf
from tensorflow.keras.models import Sequential
from tensorflow.keras.layers import InputLayer, Dense

N, Din, H, Dout = 16, 1000, 100, 10

model = Sequential()
model.add(InputLayer(input_shape=(Din,)))
model.add(Dense(units=H, activation='relu'))
model.add(Dense(units=Dout))
params = model.trainable_variables

loss_fn = tf.keras.losses.MeanSquaredError()
opt = tf.keras.optimizers.SGD(learning_rate=1e-6)

x = tf.random.normal((N, Din))
y = tf.random.normal((N, Dout))

for t in range(1000):
    with tf.GradientTape() as tape:
        y_pred = model(x)
        loss = loss_fn(y_pred, y)
        grads = tape.gradient(loss, params)
        opt.apply_gradients(zip(grads, params))
```



# Keras: High-level API

Keras gives you  
common loss  
functions and  
optimization  
algorithms

```
import tensorflow as tf
from tensorflow.keras.models import Sequential
from tensorflow.keras.layers import InputLayer, Dense

N, Din, H, Dout = 16, 1000, 100, 10

model = Sequential()
model.add(InputLayer(input_shape=(Din,)))
model.add(Dense(units=H, activation='relu'))
model.add(Dense(units=Dout))
params = model.trainable_variables

loss_fn = tf.keras.losses.MeanSquaredError()
opt = tf.keras.optimizers.SGD(learning_rate=1e-6)

x = tf.random.normal((N, Din))
y = tf.random.normal((N, Dout))

for t in range(1000):
    with tf.GradientTape() as tape:
        y_pred = model(x)
        loss = loss_fn(y_pred, y)
        grads = tape.gradient(loss, params)
        opt.apply_gradients(zip(grads, params))
```







# Keras: High-level API

Forward pass:  
Compute loss,  
build graph

Backward pass:  
compute gradients

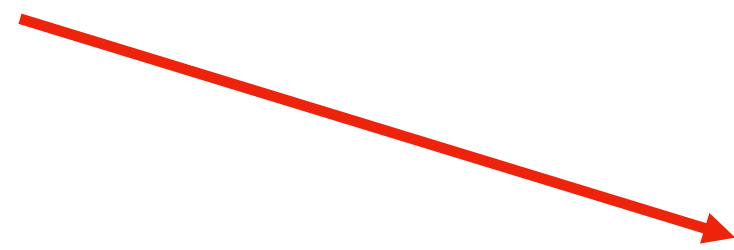

```
import tensorflow as tf
from tensorflow.keras.models import Sequential
from tensorflow.keras.layers import InputLayer, Dense

N, Din, H, Dout = 16, 1000, 100, 10

model = Sequential()
model.add(InputLayer(input_shape=(Din,)))
model.add(Dense(units=H, activation='relu'))
model.add(Dense(units=Dout))
params = model.trainable_variables

loss_fn = tf.keras.losses.MeanSquaredError()
opt = tf.keras.optimizers.SGD(learning_rate=1e-6)

x = tf.random.normal((N, Din))
y = tf.random.normal((N, Dout))

for t in range(1000):
    with tf.GradientTape() as tape:
        y_pred = model(x)
        loss = loss_fn(y_pred, y)
        grads = tape.gradient(loss, params)
    opt.apply_gradients(zip(grads, params))
```



# Keras: High-level API

```
import tensorflow as tf
from tensorflow.keras.models import Sequential
from tensorflow.keras.layers import InputLayer, Dense

N, Din, H, Dout = 16, 1000, 100, 10

model = Sequential()
model.add(InputLayer(input_shape=(Din,)))
model.add(Dense(units=H, activation='relu'))
model.add(Dense(units=Dout))
params = model.trainable_variables

loss_fn = tf.keras.losses.MeanSquaredError()
opt = tf.keras.optimizers.SGD(learning_rate=1e-6)

x = tf.random.normal((N, Din))
y = tf.random.normal((N, Dout))

for t in range(1000):
    with tf.GradientTape() as tape:
        y_pred = model(x)
        loss = loss_fn(y_pred, y)
        grads = tape.gradient(loss, params)
        opt.apply_gradients(zip(grads, params))
```

Optimizer object updates parameters

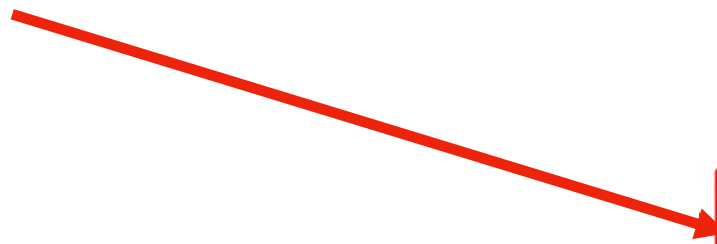



# Keras: High-level API

Define a function  
that returns the loss

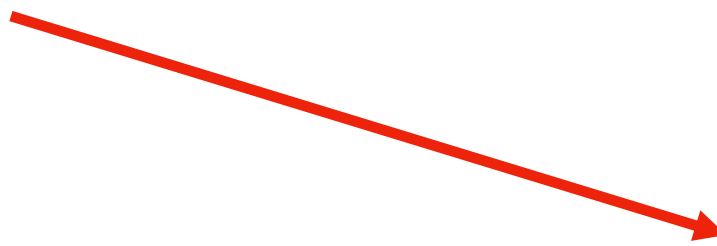

```
import tensorflow as tf
from tensorflow.keras.models import Sequential
from tensorflow.keras.layers import InputLayer, Dense

N, Din, H, Dout = 16, 1000, 100, 10

model = Sequential()
model.add(InputLayer(input_shape=(Din,)))
model.add(Dense(units=H, activation='relu'))
model.add(Dense(units=Dout))

params = model.trainable_variables

loss_fn = tf.keras.losses.MeanSquaredError()
opt = tf.keras.optimizers.SGD(learning_rate=1e-6)

x = tf.random.normal((N, Din))
y = tf.random.normal((N, Dout))

def step():
    y_pred = model(x)
    loss = loss_fn(y_pred, y)
    return loss

for t in range(1000):
    opt.minimize(step, params)
```



# Keras: High-level API

Optimizer computes  
gradients and  
updates parameters

```
import tensorflow as tf
from tensorflow.keras.models import Sequential
from tensorflow.keras.layers import InputLayer, Dense

N, Din, H, Dout = 16, 1000, 100, 10

model = Sequential()
model.add(InputLayer(input_shape=(Din,)))
model.add(Dense(units=H, activation='relu'))
model.add(Dense(units=Dout))

params = model.trainable_variables

loss_fn = tf.keras.losses.MeanSquaredError()
opt = tf.keras.optimizers.SGD(learning_rate=1e-6)

x = tf.random.normal((N, Din))
y = tf.random.normal((N, Dout))

def step():
    y_pred = model(x)
    loss = loss_fn(y_pred, y)
    return loss

for t in range(1000):
    opt.minimize(step, params)
```

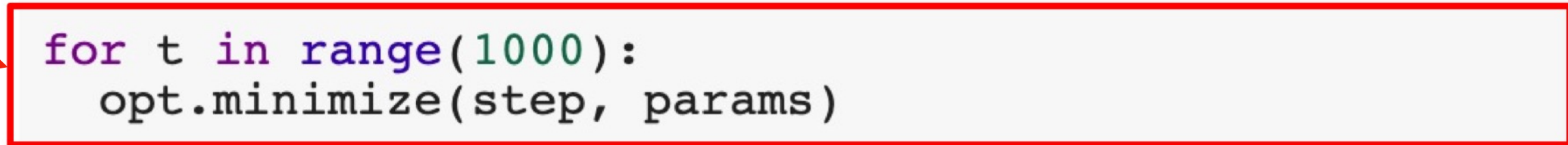
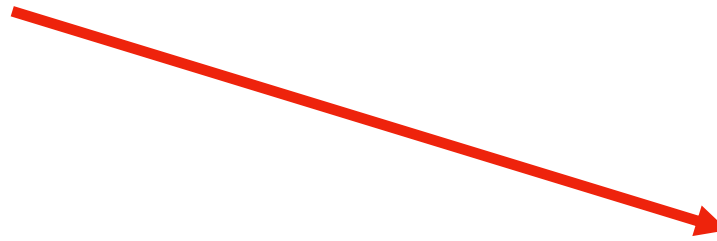



# TensorBoard

Add logging to code to record loss, stats, etc  
Run server and get pretty graphs!

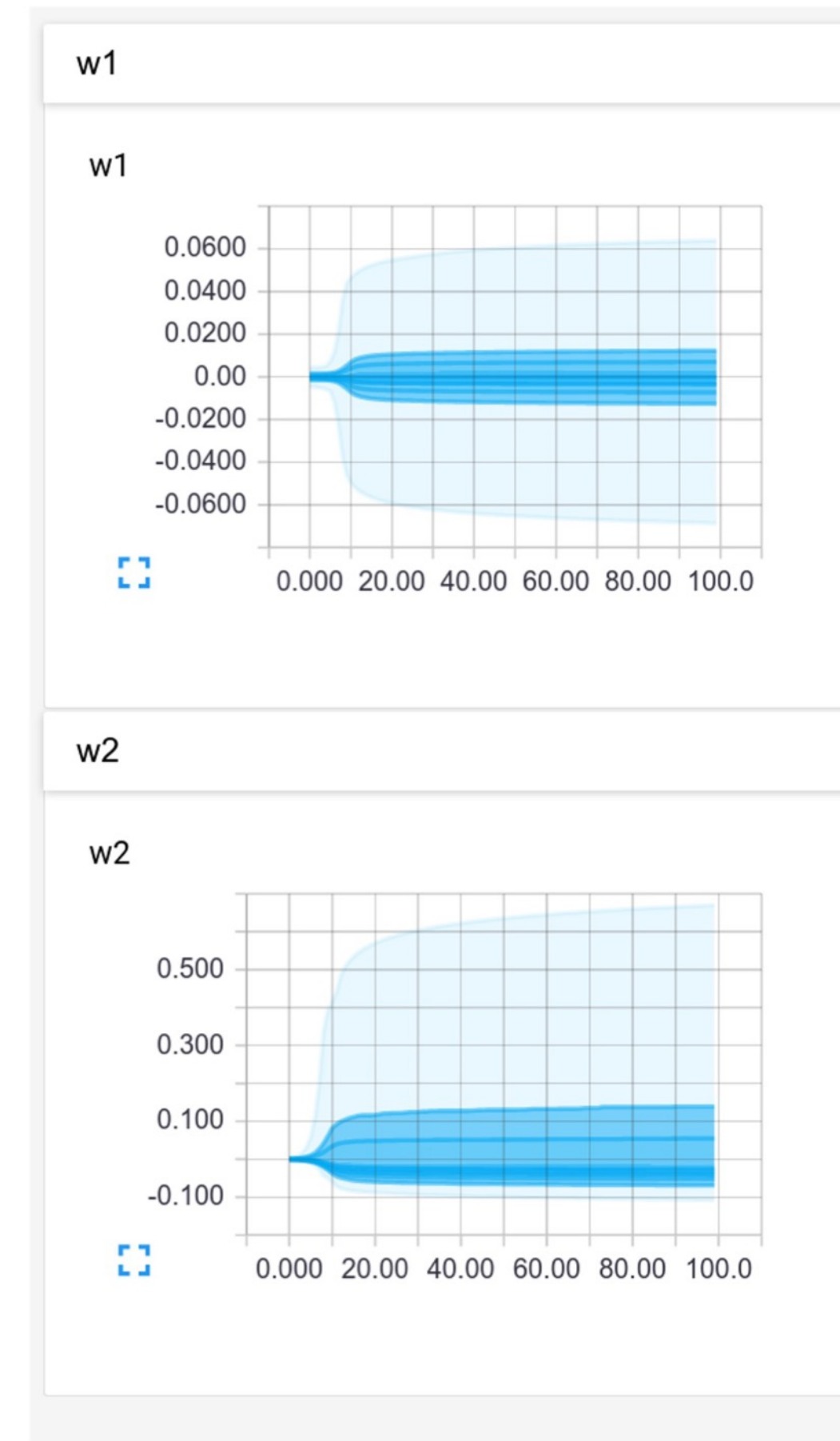
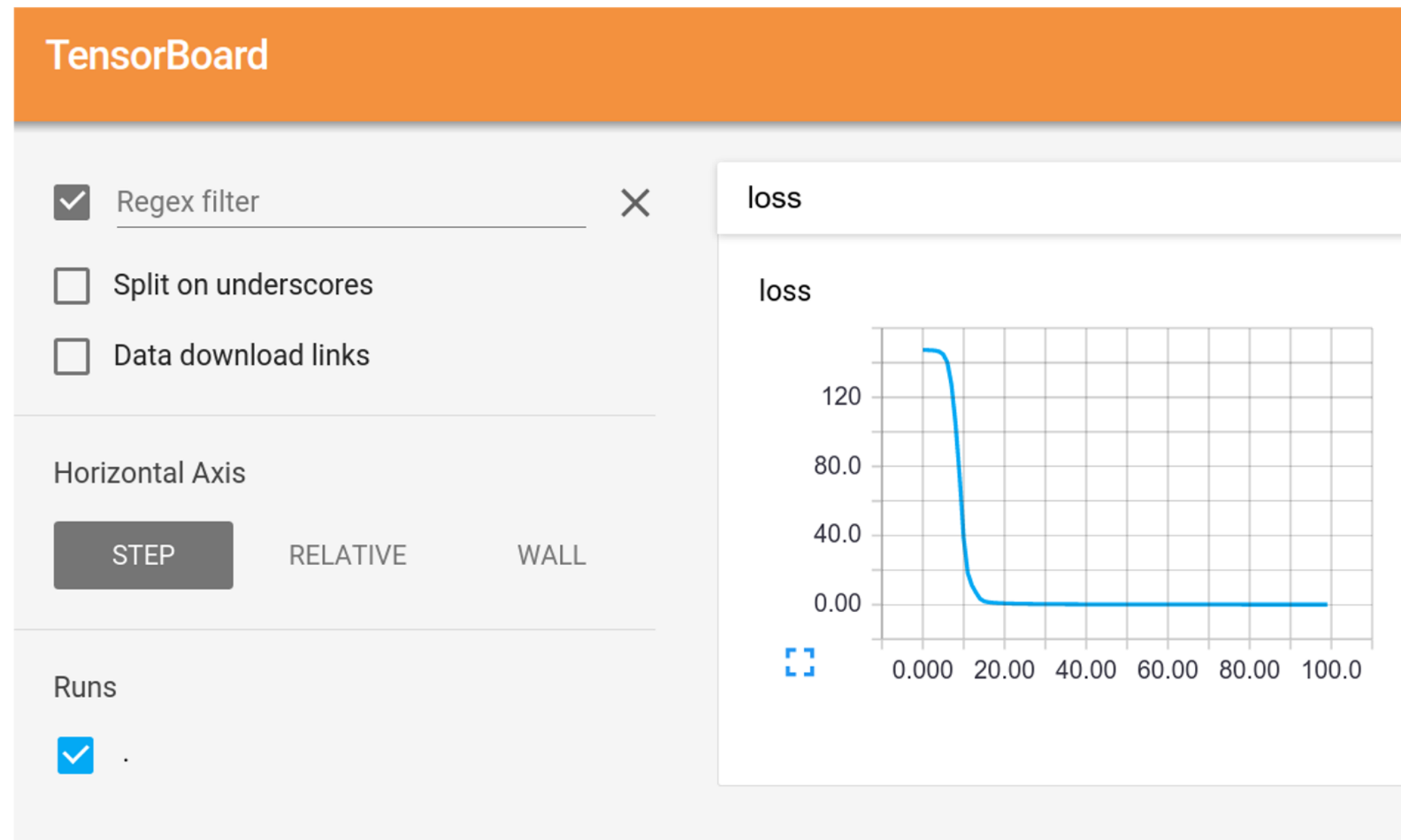



# Summary: PyTorch vs TensorFlow

---

- **Pytorch**
  - Clean, imperative API
  - **Dynamic** graphs for easy debugging
  - JIT allows static graphs for production
  - Hard/inefficient to use on TPUs
  - Not easy to deploy on mobile
- **Tensorflow 1.0**: **static** graphs by default; can be confusing to debug; API could be messy
- **Tensorflow 2.0**: dynamic by default; standardized on **Keras** API



# DEEP ROB

Lecture 12  
Deep Learning Software  
University of Michigan | Department of Robotics